

The FT-500Pro is the professional grade version of the FT-50W wider model. This version includes high-end meter gauges for checking vertical and horizontal shaking of the bicycle wheel much more precisely when compared to traditional scratch-sound systems.

*Read this instruction manual carefully before use.
Keep this manual in hand while you use this product.*

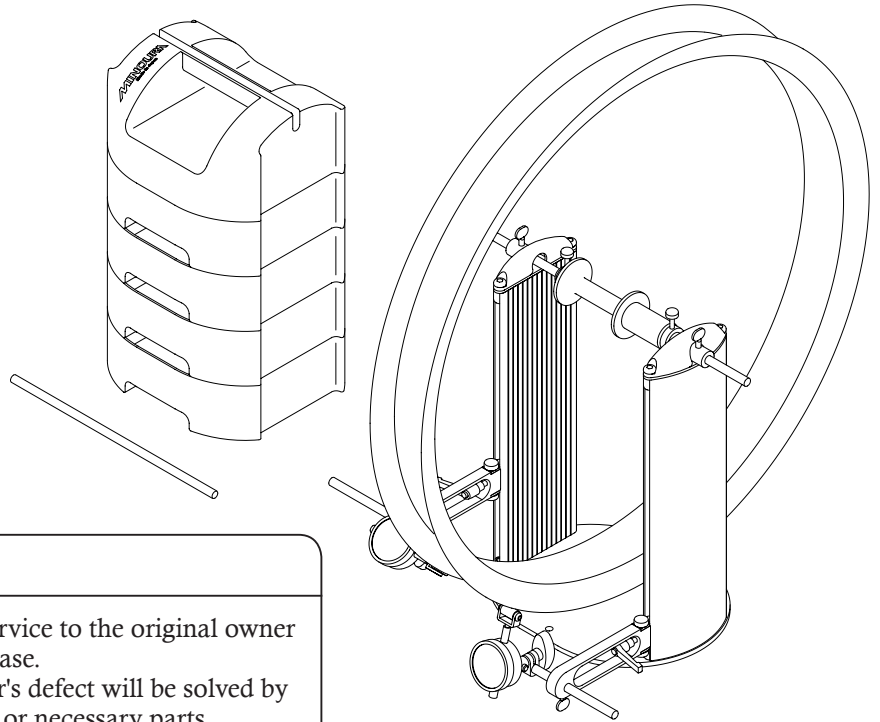

[In-use image with wide rim wheel]

Warranty Period : 1 year

Minoura offers 1-year limited warranty service to the original owner of this product from the date of the purchase. Any problems caused by the manufacturer's defect will be solved by free repair or replacing the whole product or necessary parts. However, any problems caused by user's misuse, unapproved modification and disassembling, damage during use or shipping, or expected natural wear will not be covered by this program. Please read the enclosed warranty card for more details. And Minoura strongly suggests to check out our web site regularly for the latest update.



Important Notes

- FT-500Pro is a special tool for precisely maintaining the bicycle wheel. Do not use this product for any other purpose than instructed.
- Remove the quick release (Q/R) skewer from your wheel before use.
- We also recommend removing the tire from the wheel before use.
- The max wheel hub width is 210mm that covers most wide rims for fat bikes. Remove the spring from the right side coupling axle when you mount a very wide hub.
- Clamps on a standard 9mm Q/R using the side couplings.
- 12mm or 15mm thru axle type hubs are also compatible. Insert the supplied adapters in the hub hole for mounting.
- Please note that a small amount of rim surface scratches from the roller is normal. Especially on carbon or softer metal wheels. But it's much less than standard scratching mechanism and safer.
- Do not spin the wheel too fast. Rotate slowly.
- The verticality of the pillar is the most important matter on FT-500Pro. Do not apply any shock or damage to the pillars even while storing.
- Your wheels are critical to your riding safety. You assume all responsibility for working on your wheels. Minoura is not responsible for any issues that might arise from truing your wheels. If you have doubts, please take your wheels to a professional mechanic for service.
- Minoura is not responsible for any issues encountered with your wheels after using the product. Make sure you know what you're doing. If you have any doubts in your abilities, consult a professional. Minoura is supplying tool to do a job, but learning how to use this tool is your responsibility.

Contact

If you have question or problem on this product, please contact the shop where you originally purchase this product or the distributor in your country first. The distributor information can be found on our web site. Only when you cannot obtain enough service from them, you can contact Minoura directly.

MINOURA JAPAN

(for ALL customers, including Canada)

1197-1 Godo, Anpachi, Gifu 503-2305 Japan

Fax +81-584-27-7505

Mail minoura@minoura.jp / URL www.minoura.jp

MINOURA NORTH AMERICAN TECH CENTER

(for U.S. residents ONLY)

Mon - Fri, 9 am - 5 pm (PCT)

Phone 1-510-538-8599 / Fax 1-510-538-5899

Mail support@minourausa.com

Schematics

(In this manual, we are explaining with the horizontal shaking gauge mounted on the left side. But you can set the stand up for use on the right side, too..)

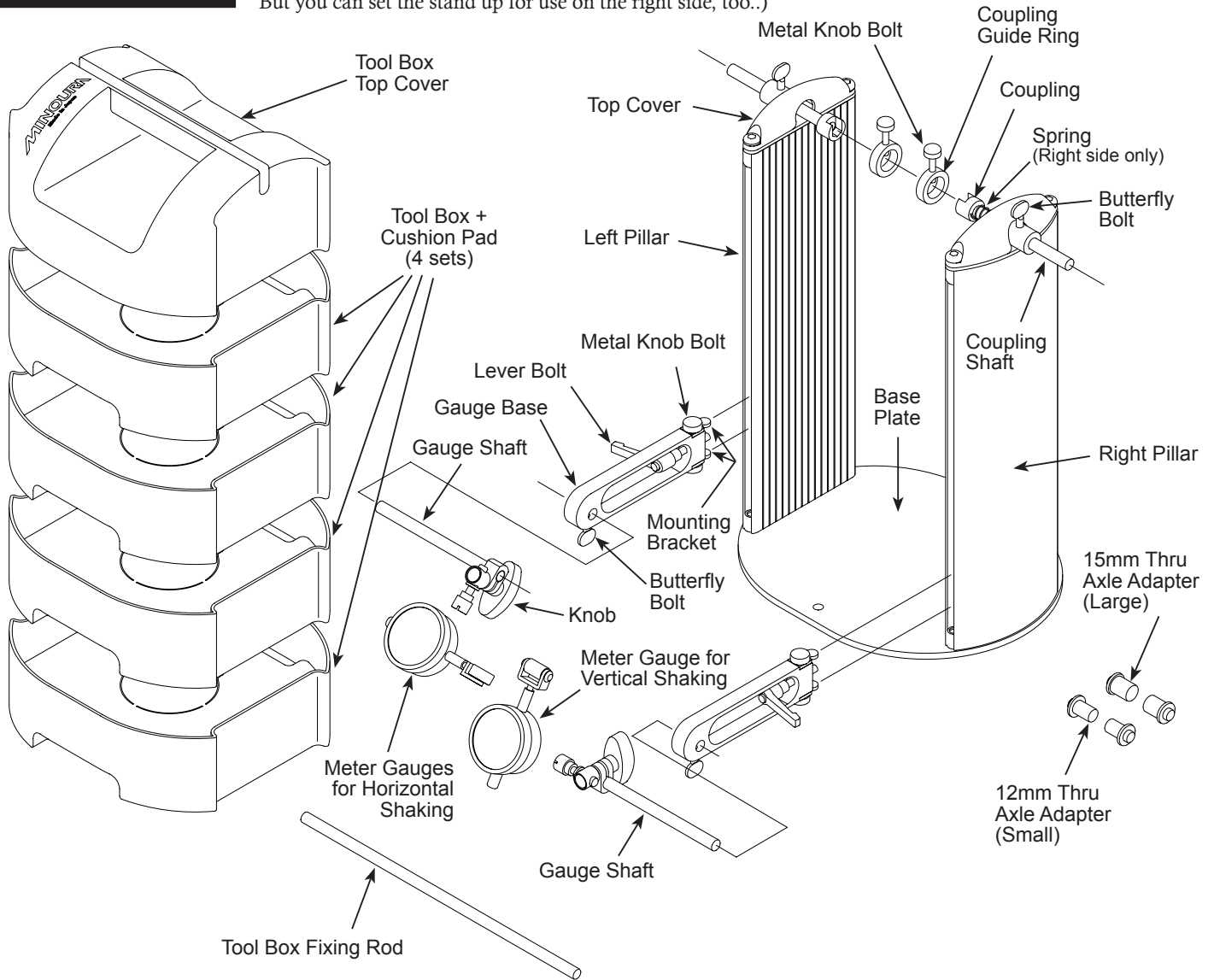

How To Assemble

Required Tool : 5mm Hex Wrench

- 1 Grab the handle of the top cover, and pull upward the FT-500Pro from the box, then place on your work bench.

The rod works to keep the stacked tool boxes in position together with the stand for easier carrying.

It is temporarily not fixed in the box, so please be careful not take the rod off from the hole.

The rod can be removed by pushing the edge by your finger. (Fig. A)

You should fix the rod position by using the butterfly bolts which usually work to hold the coupling shaft when you carry the FT-500Pro.

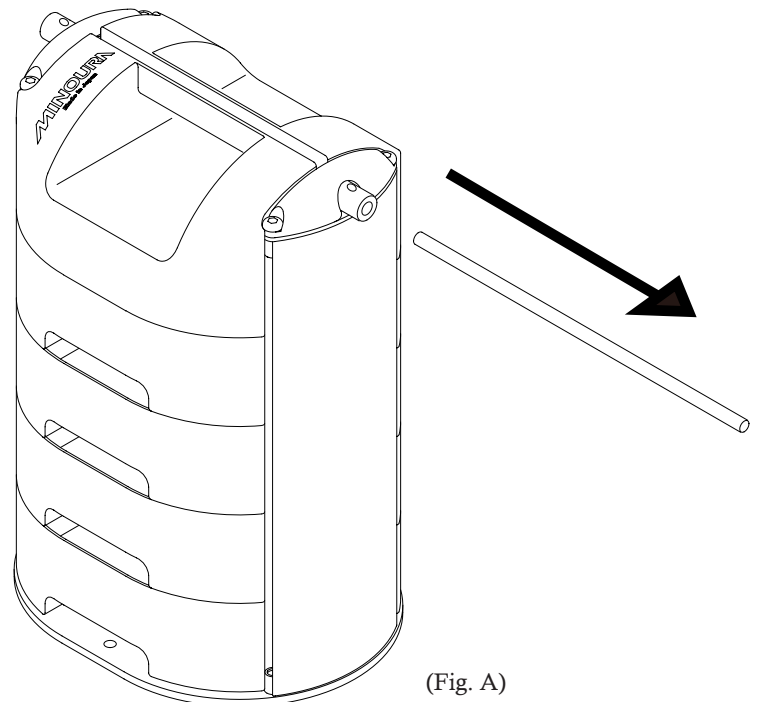

(Fig. A)

- 2** There is a total of four tool boxes stacked on top of each other. They can be removed by lifting them upward. (Fig. B)

You will see all necessary parts and adapters in the boxes.

Also you can use this space for storing your own parts and tools.



The boxes are not connected. You need to pull them out one by one, or grab the bottom box to lift all boxes up together.



You must stack every box tightly as the bottom rib is completely hidden in the lower box, otherwise the fixing rod cannot be set in the last step.

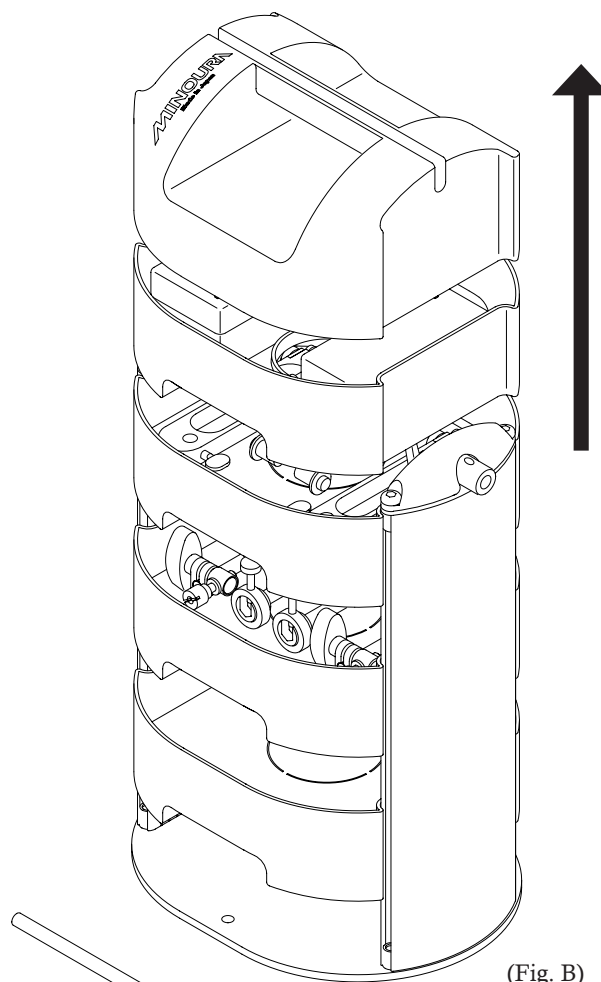

(Fig. B)

- 3** Take out the butterfly bolts from the tool box, and screw it in the thread hole on top of the pillar. (Fig. C)

After removal of all boxes, you will install the gauges and coupling shafts onto the body.

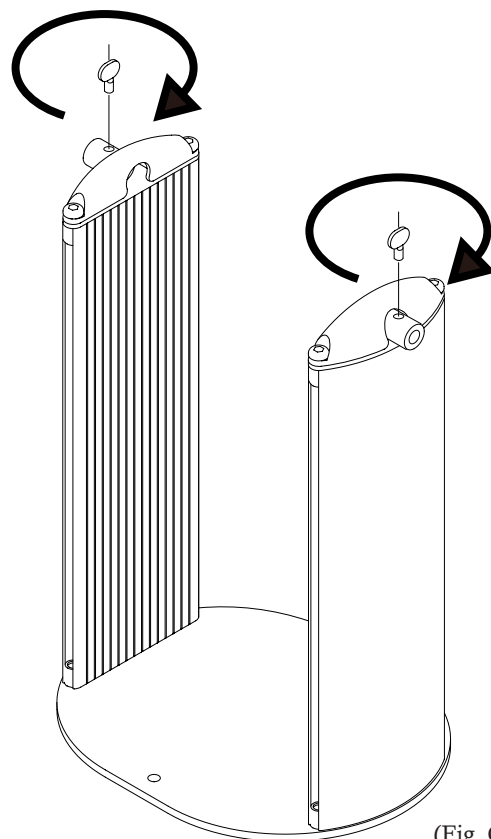
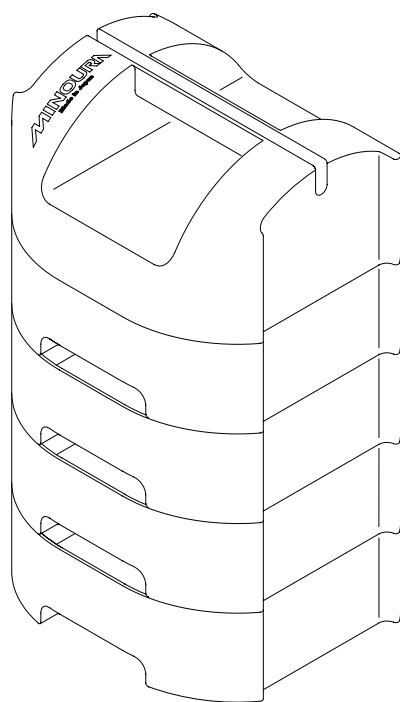

(Fig. C)

4

All 4 boxes are exactly the same.

To store a lubricant can or long tools such as a spanner or screwdriver, cut the center section of the cushion pad to make a hole, and insert the tool into the hole.



Please note that it's difficult to repair the cushion if you modify it. Think carefully before cutting the cushion about your future needs.

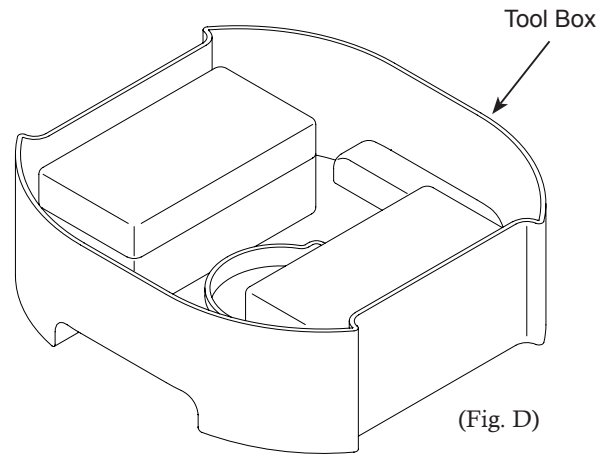

- Meter Gauge for Vertical Shaking
- Meter Gauge for Horizontal Shaking

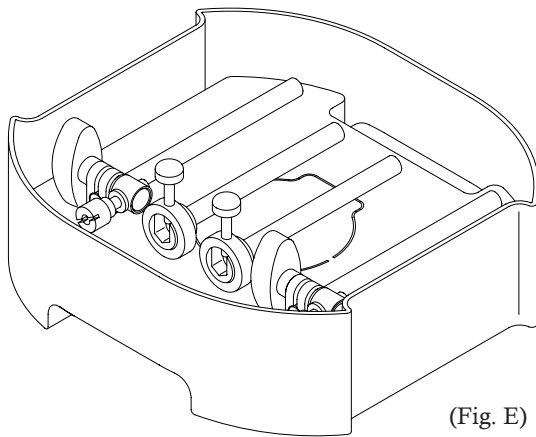

- Coupling Shaft x 2
- Gauge Shaft x 2

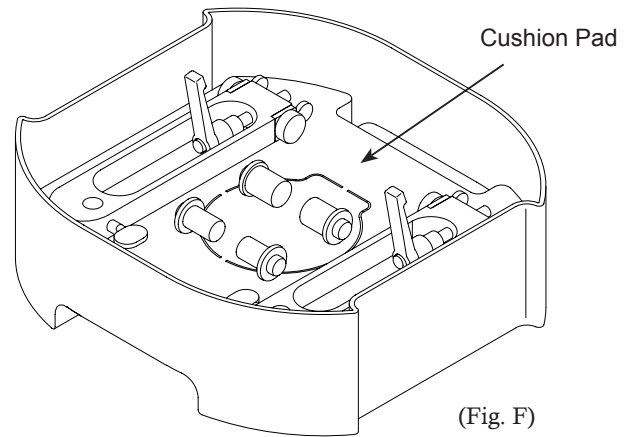

- Gauge Base x 2
- 12mm Thru Axle Adapter x 2
- 15mm Thru Axle Adapter x 2

5

Install the coupling shafts on top of the pillars, and set the coupling ring on each coupling. (Fig. G)

The body is symmetric and the coupling shafts are exactly the same.

(We are installing the spring on the right side coupling in this manual. Of course, setting on left side is no problem.)

Insert a coupling shaft in the spring and set in the hole on the right side pillar. Tighten the butterfly bolt temporarily.

On the left side, the coupling shaft doesn't have a spring.

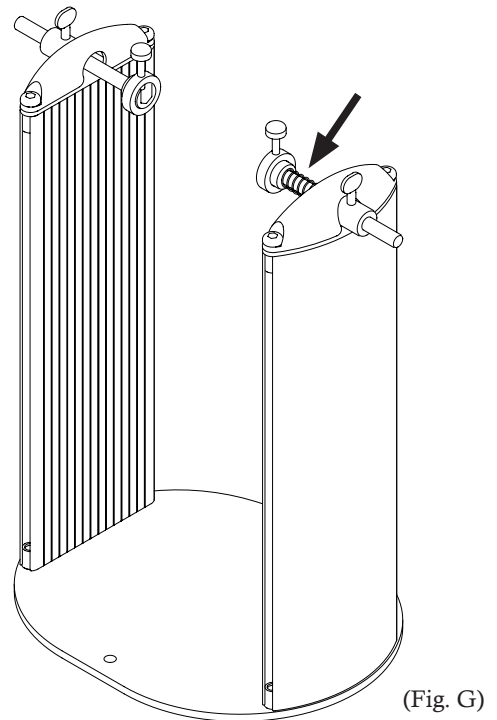

- 6** Install the gauge bases to the pillar rail.
Remove the mounting brackets from the gauge base, and put it into the pillar rail (Fig. H).
Flip the bracket vertical to insert (Fig. I), and flip horizontal back to hold (Fig. J).

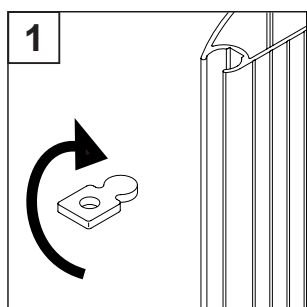

(Fig. H)

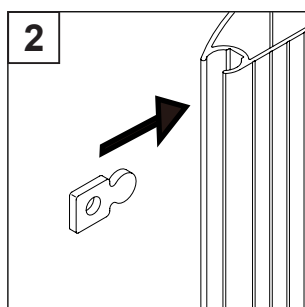

(Fig. I)

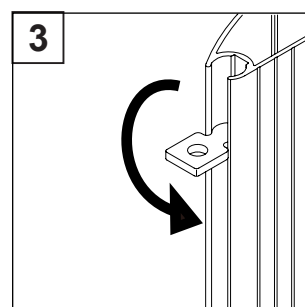

(Fig. J)

- 7** Sandwich the gauge base with the brackets from top and bottom, and screw the metal knob bolts to mount.
The gauge base will be held in position by screwing the inside lever bolt which pushes toward the wall.

You will change the gauge height later, so you don't need to tighten the lever bolt so firmly yet.

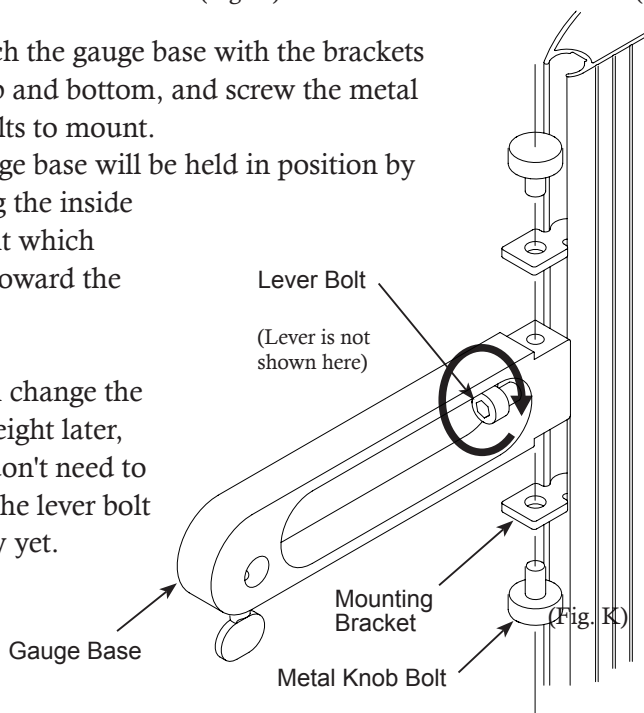

There is some clearance between the bracket and the rail. That means the gauge base may not be fixed in exactly the right angle to the pillar. Even if it's a little slanted, it's not a problem.



Screwing the lever bolt will pull the gauge base against the pillar and holds the gauge base solidly. However, tightening excessively will cause damage to the alloy rail tips and may cause the unit to not work properly. Do not overtighten the bolt.

TIPS: About Lever Bolt

The lever bolt has a spring inside between the threaded bolt and the plastic lever. You are free to set the lever at any angle as you want by pulling the lever while turning.
To fix the gauge base, turn the lever to tighten, pull the lever to get back to the previous angle, and repeat the steps to tighten more.

- 8** Take out the meter gauge from the container. Twist and remove the tip piece. (Fig. L)
Put the supplied spring on the telescopic shaft. (Fig. M)

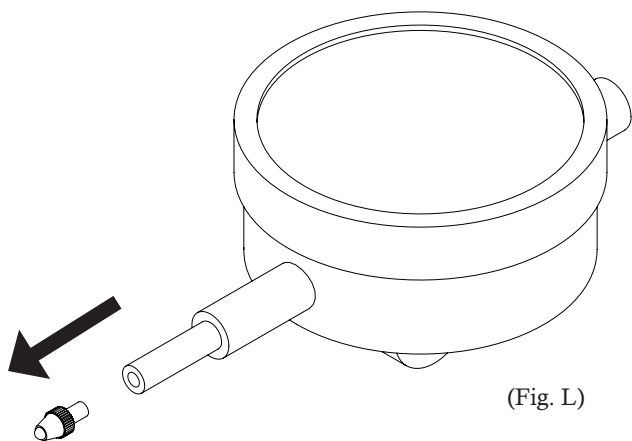

(Fig. L)

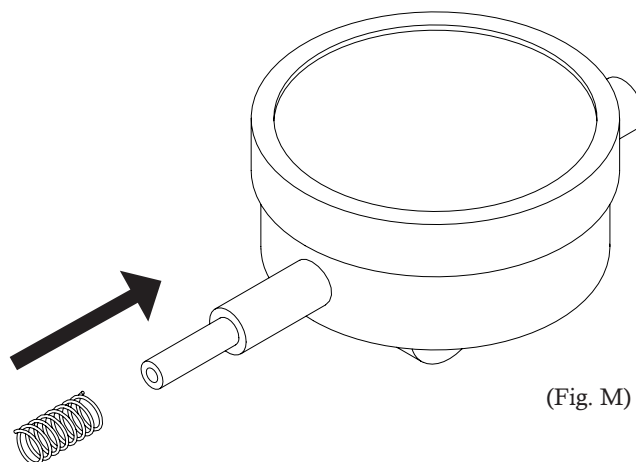

(Fig. M)

9 [How To Assemble Horizontal Gauge] (Required Tool : 2mm Hex Wrench)

- 1) Install the L-shaped bracket onto the telescopic shaft with the supplied M3 cap bolt and tighten it with the 2mm hex wrench carefully.
- 2) Assemble the roller and the flat washer to the L-shaped bracket with the shorter couple bolt. Tighten the bolt with the 2mm hex wrench. No tool required on the nut side.

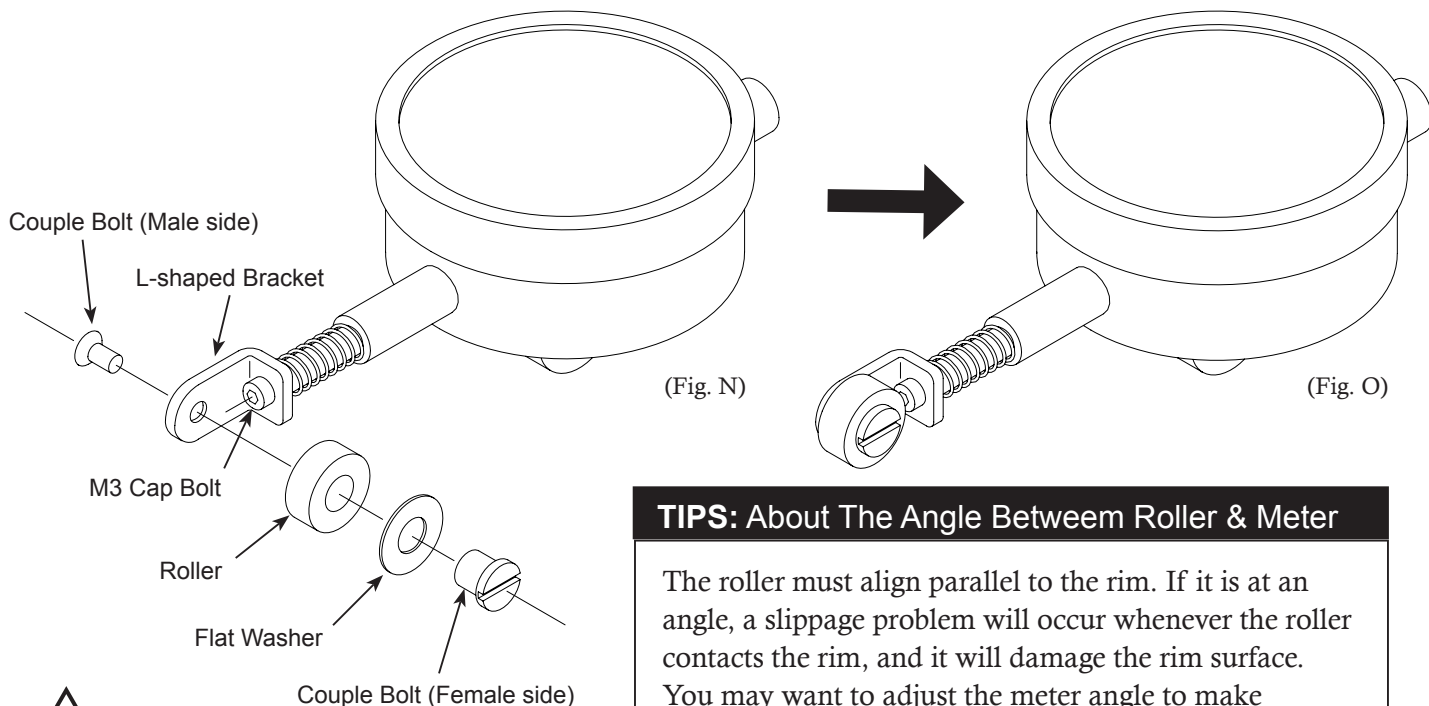

Do NOT over-tighten the M3 bolt on the telescopic shaft. This may cause the meter gauge to break which is very expensive to replace.

TIPS: About The Angle Between Roller & Meter

The roller must align parallel to the rim. If it is at an angle, a slippage problem will occur whenever the roller contacts the rim, and it will damage the rim surface. You may want to adjust the meter angle to make checking the indicator easier. It means the angle between the roller and the meter should not be 90 degrees but different. This means you will change the roller angle after you actually mount the wheel on the FT-500Pro.

10 [How To Assemble Vertical Gauge] (Required Tool : 2mm Hex Wrench x1, 3mm Hex Wrench x2)

- 1) Install the roller holder onto the telescopic shaft with the supplied M3 cap bolt and tighten with the 2mm hex wrench carefully.
- 2) Put the roller in the holder and secure it with the longer couple bolt. Apply the 3mm hex wrench on each side and twist them to tighten firmly.

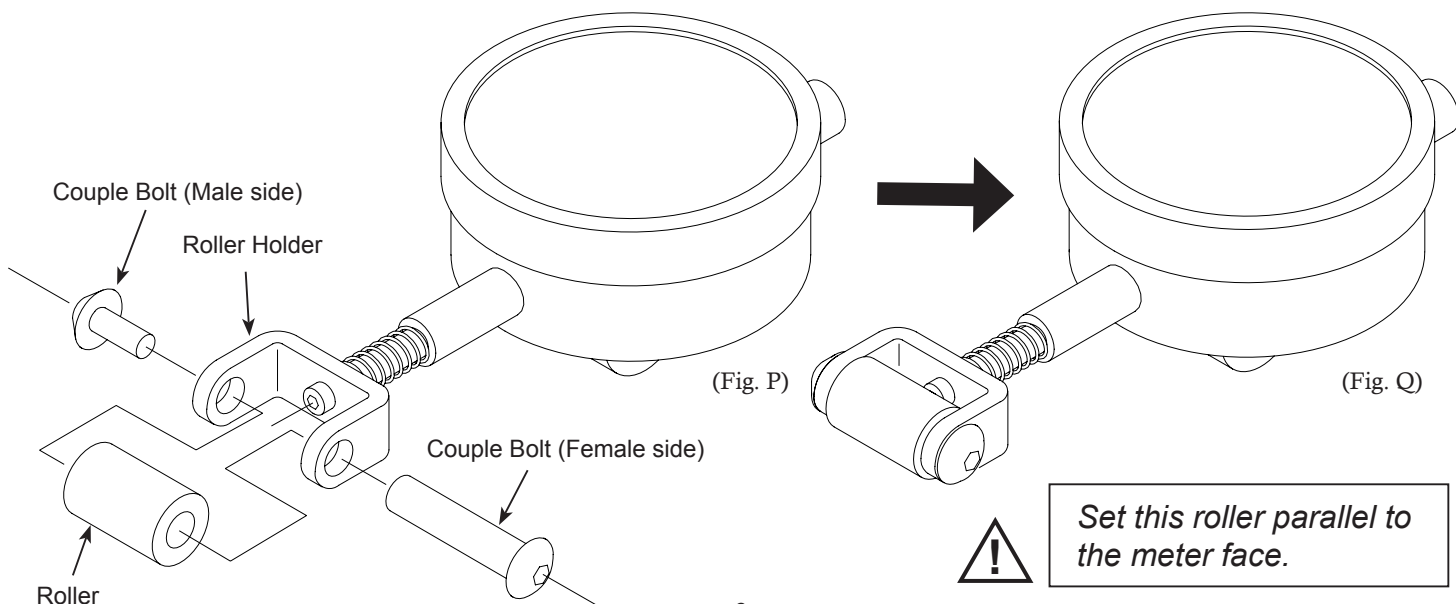

- 11** Install the meter gauge to the gauge shaft.
(In this manual, we set the horizontal shaking gauge on the left side, and vertical shaking gauge on the right side. You may set them in the opposite pattern if desired.)

Remove the meter nut from the gauge shaft.
Put the gauge axle through the hole on the backside bracket of the meter, and tighten the nut. (Fig. R)



*Do NOT loosen the large knob while you set the meter gauge to the shaft.
Loosening the knob will automatically loosen the holding of the meter axle. Unexpected meter axle removal or the meter might fall off if loosened too much.*

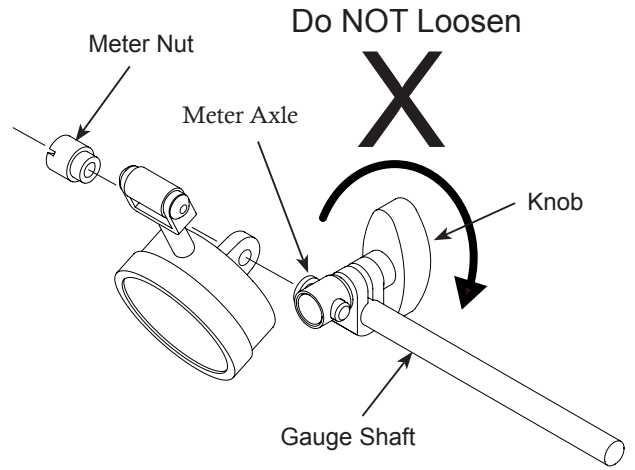

(Fig. R)

- 12** Loosen the butterfly bolt under the gauge base, and put the gauge shaft through the hole from inside.

You will set the meter position after mounting the actual wheel. (Fig. S)

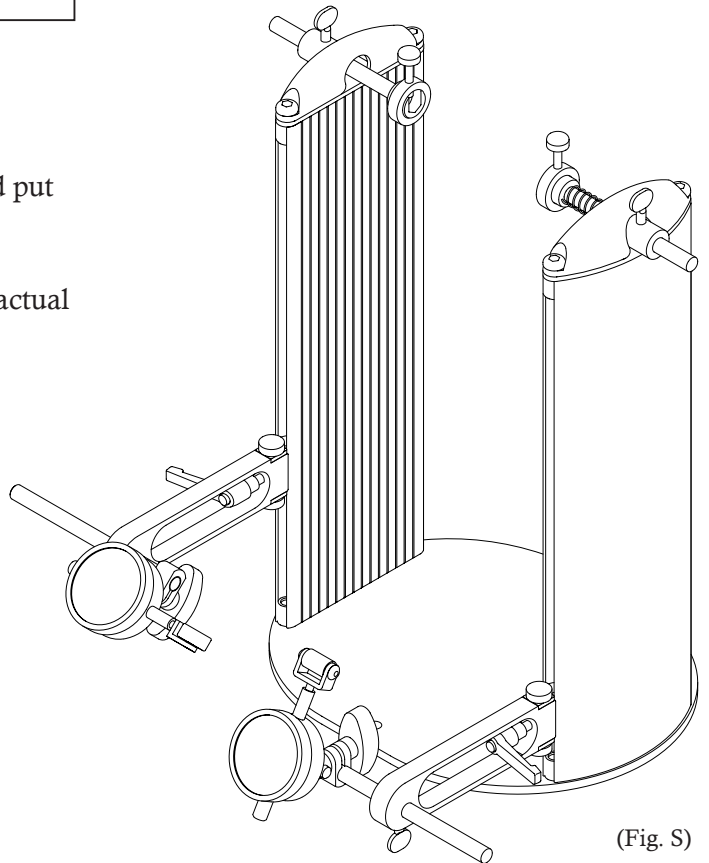

(Fig. S)

How To Mount Wheel

9mm Quick Release Skewer Hub

12mm / 15mm Thru Axle Hub

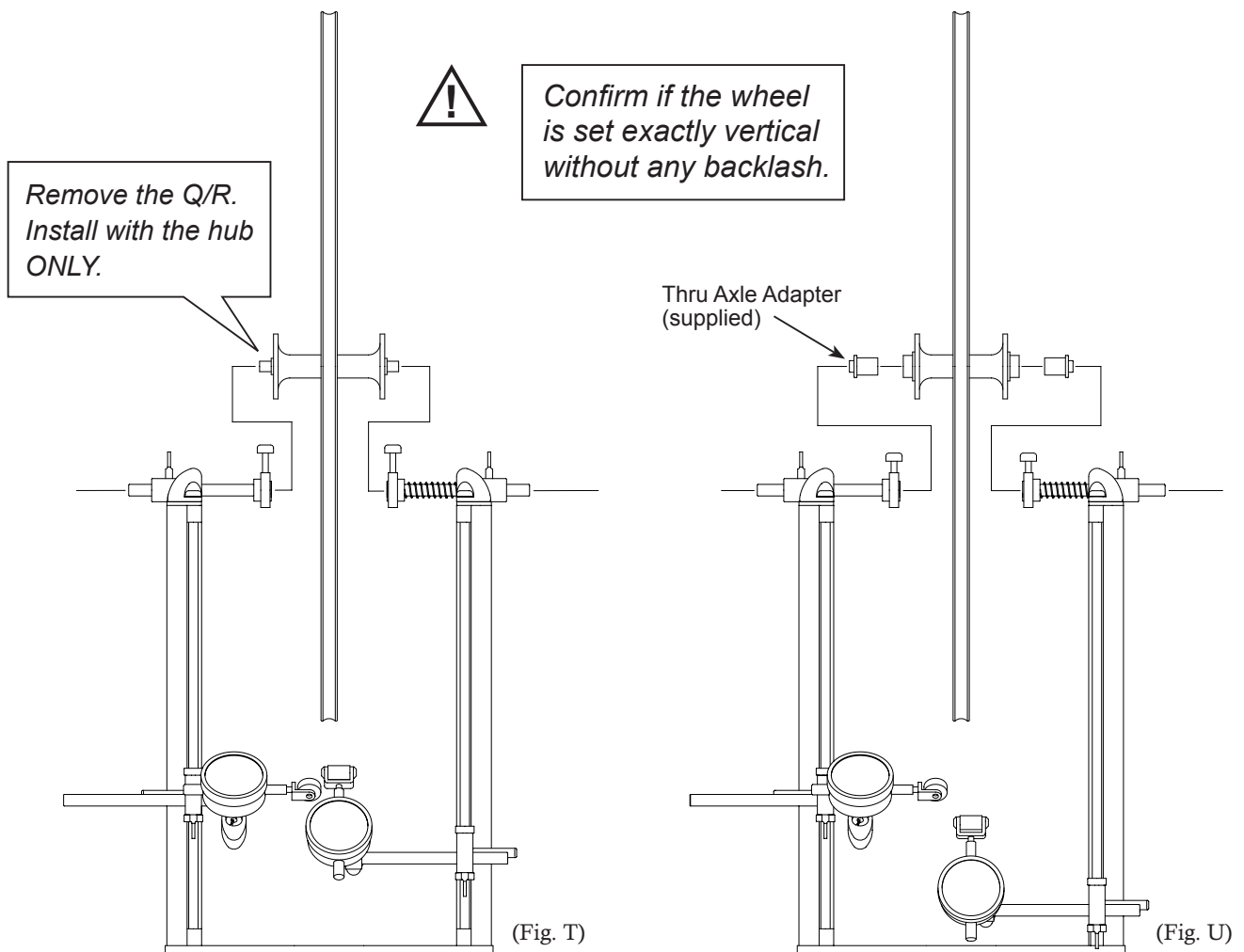

Twist the couplings as the open side faces top, and set the wheel as both side couplings clamp the hub. After clamping, tighten the butterfly bolt on the top cover to fix the position. (Fig. T)

It's crucial that each hub end sits in the deepest position in the coupling and make sure that both right and left ends are set in the same height. This is critical in order to obtain the correct result. For this purpose, you should tighten the metal knob bolt on the coupling guide ring to push down and hold the hub axle.

In case of thru axle hub, insert the supplied adapter in the hub hole before mounting. (Fig. U)

TIPS!

Make sure there is a spring in the right side coupling shaft. The spring helps pushing the hub towards the clamp for a better fit.

Temporarily hold the right side coupling as the spring is compressed, place the wheel, and set the left side coupling position. This means even if you loosen the butterfly bolt on the right side coupling, it still continues pushing the hub.

This is also good to know if the wheel is finished symmetrically by flipping the wheel while retracting the right side coupling only (do not move the left side coupling).

It's almost the same as when you use a dishing tool.

How To True The Wheel

Adjust the both side coupling shaft lengths equally in order to get the wheel in the center of the stand as closely as possible. Tighten the left side butterfly bolt firmly and tighten the right side bolt gently.

At first, loosen the butterfly bolt and the knob to move the vertical shaking meter gauge roller in contact with the rim edge.

(Make sure you remove the tire from your wheel when checking vertical shaking.)

Next, move the horizontal shaking meter gauge roller in contact with the rim wall.

Tighten every butterfly bolt and knob bolt to fix the positions.

You should check the horizontal shaking at the area where the brake shoe touches the rim. This area is resistant to scratching.

If your rim has a shallow wall like disc brake rims, it may be difficult to keep the rim from being scratched. Carefully choose the right areas for contact.

If the wheel has a tire and it has contacted with the gauge or shaft, or the gauge roller cannot reach the rim, you need to remove the tire from the rim.

Rotate the wheel slowly, and watch the meter indicator. If the rim is shaking and it comes closer to the meter gauge, the indicator will change.

Increasing the indicator means the rim is approaching toward the meter. You need to tighten the spoke nipples that comes from opposite side to pull the rim further.

Decreasing the indicator means the rim is departing from the meter. You need to tighten the spoke nipples on the same side to come closer.

Here both side couplings are set in the correct position and the wheel is perfectly vertical.

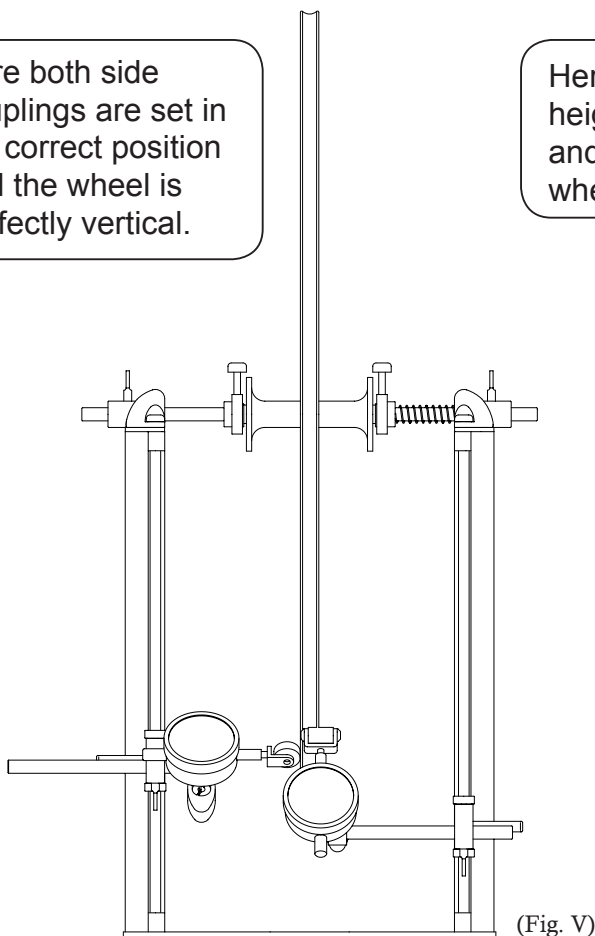

Here the hub end height is different and you can see the wheel is slanted.

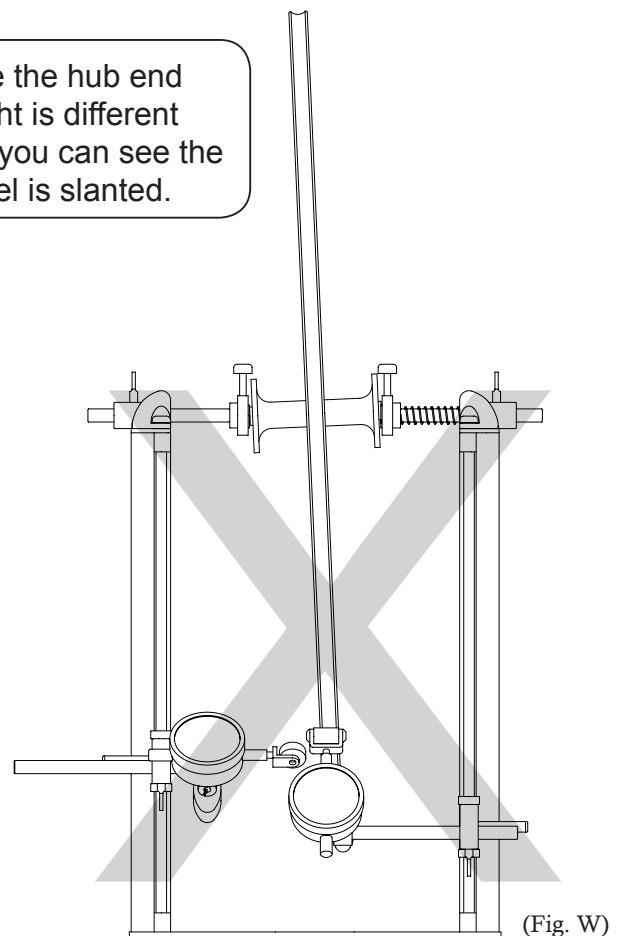

Repeat these actions until the indicator doesn't move and stay in the same level as you rotate the wheel.
At this time, you need to check if the wheel is finished perfectly symmetrical. It is more important than fixing the rim shaking.
Occasionally remove the wheel from the stand and check the wheel symmetry by using the wheel dishing tool (sold separately).

FYI, You can check symmetry without using the dishing tool by the following steps;

1. Tighten the butterfly bolt and fix the left side coupling position.
2. Remove the wheel by loosening the right side coupling ONLY.
3. Flip the wheel and set it again.
4. Check the meter indicator. If it sits in the same level, it means the wheel is finished perfectly symmetrical. If not, it means the wheel is still far from the center.

Finally, check if the spoke tension is properly set by the spoke tension meter (sold separately).

Direct Mounting

You can fix the FT-500Pro to your work bench directly with M8 bolts if you need a more solid base. (Fig. X)
The hole pitch is 190mm.

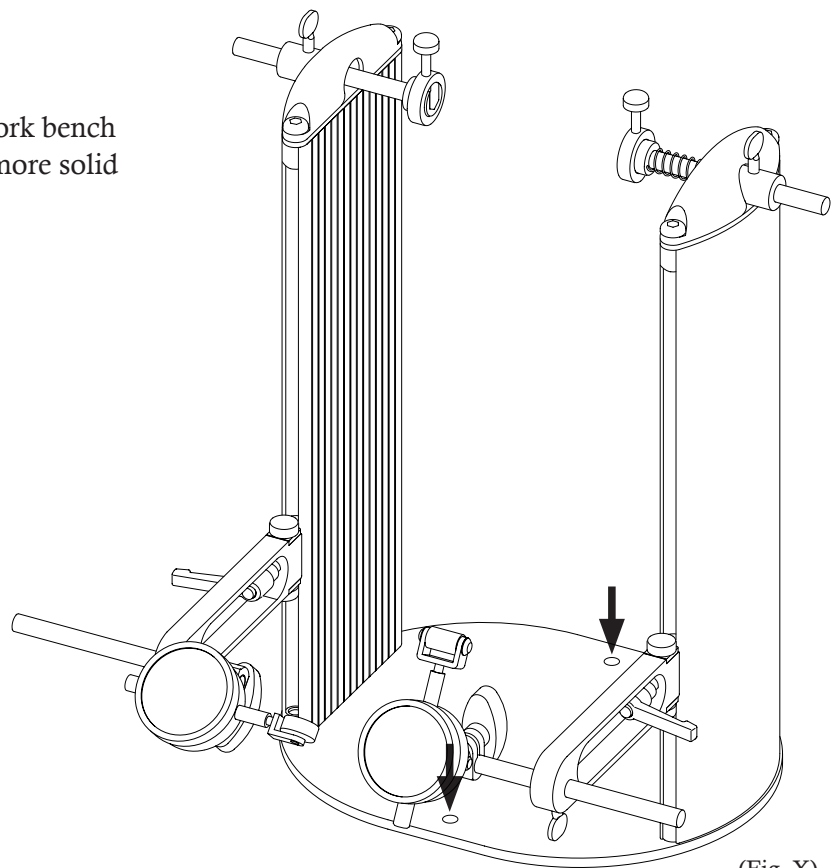

(Fig. X)