

[Applicable Wheelbase Size]

950mm – 1,080mm

(Only over 26-inch wheel)

Warranty Period : 1 year

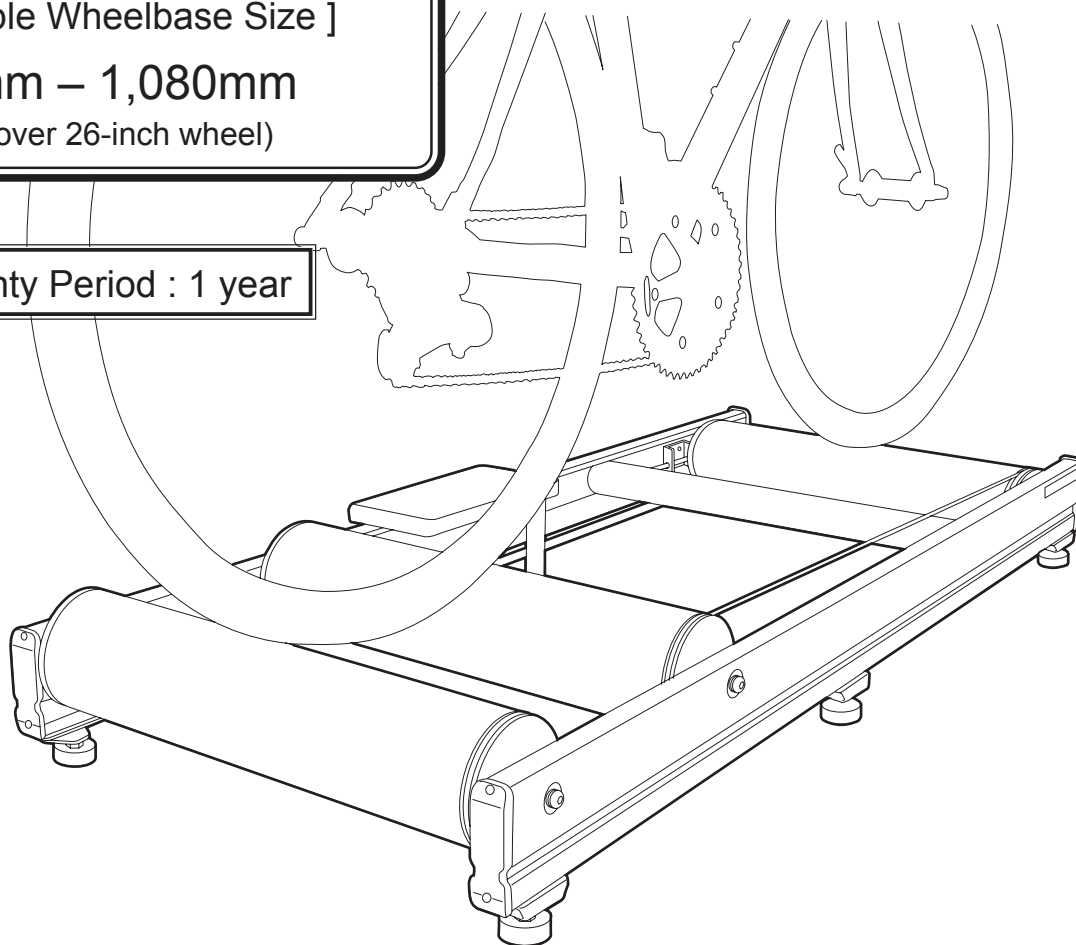

Features

- Non-foldable light alloy frame designed for durable, high speed training.
- All 3 roller drums are set at precisely different height levels independently for a smooth and natural pedaling feel that keeps the bike exactly level.
- The combination of tough, special roller drums with thicker material and machined heavyweight steel roller caps that perform as flywheels. And combined with larger diameter roller axles and bigger bearings this provides a very smooth, quiet, solid and steady riding feel.
- Precisely adjustable front roller positioning system fits perfectly to every bike frame.
- High quality wooden step is included on the left side frame.

Cautions

*Triple roller trainers require riders to maintain balance without the help of any accessories or devices.
Make sure you can balance yourself on rollers before attempting to ride.*

Contact

If you have any questions or need help, you should contact the dealer where you purchased the rollers or the Minoura distributor in your country first. If you cannot get satisfaction, then please contact us.

MINOURA JAPAN (for ALL customers)
134-1 Shimomiya, Godo, Anpachi, Gifu, Japan
Fax: +81-584-27-7505 / Mail: minoura@minoura.jp
Web: www.minoura.jp

MINOURA North America (for U.S. residents ONLY)
California, U.S.A.
Phone: 1-510-538-8599 / Fax: 1-510-538-5899
Mail: support@minourausa.com

- *For a standard 2-wheel bike with the wheelbase size between 950mm and 1,080mm only. Any other bikes like tandems, recumbent, folding bikes or bikes without the applicable wheelbase range cannot be used on R800.*
- *Triple roller trainers require the rider to be balanced at all times. If you are new to rollers it is strongly recommended that you set the R800 next to a wall or handrail so you can use either to regain your balance should the need arise.
Falling off can cause injury. Keep the ground around the R800 free from clutter.*
- *R800 is height adjustable to compensate for uneven or slanted floors. The rollers should be set on a flat surface with the rollers making contact completely with the floor. Riding on a slanted floor may cause imbalance issues and could result in damage or injury if you don't adjust the foot height correctly.*
- *R800 is packed in the pre-assembled. You can use it upon opening the box.
A 5mm hex wrench is required to adjust the front roller position. It doesn't come with the rollers.*
- *Set the front roller completely parallel to the other rollers, not at an angle. If you set it in wrong position (for example, the right side is further than the left side), it will cause noise, damage or compromise alignment and stability.*
- *Keep both hands on your handlebars at all times while on the R800.
Do not brake while on the rollers. Doing so may cause a serious accident.
Simply stop pedaling and wait for the bike to stop when quitting your training session.*
- *Do not touch the spinning wheel or rollers. A serious injury may occur.
Keep kids and pets away from the trainer while using. Make sure the spinning rollers don't touch the long haired carpet directly.*
- *Indoor training traps more heat than when you train outdoors. Be sure you are healthy enough to attempt exercise indoors and on a roller. Consult a health care professional before attempting any workout regime.*
- *Sweat can cause stains on roller parts and your floor. It is recommended to use a mat between the rollers and your floor.*
- *If you feel any strange noise or smell anything burning while using R800, stop exercise immediately and ask your shop where you purchased R800. Do not try to disassemble or modify the product without prior approval from Minoura.*
- *Minoura offers a 1-year limited warranty to this product from the date of purchase for the owner who originally purchased it in brand-new condition at Minoura authorized dealer. Any other problems than the things caused by manufacturer's defect such as natural wear will not be covered by this program.
For more detail, please refer the attached "Minoura Limited Warranty Policy" card and Minoura web site.*
- **Note:** *Accessories designed for other Minoura rollers are not compatible with R800. This includes other foot steps, front wheel guards, Mag units, or carrying bags.*

Part Names

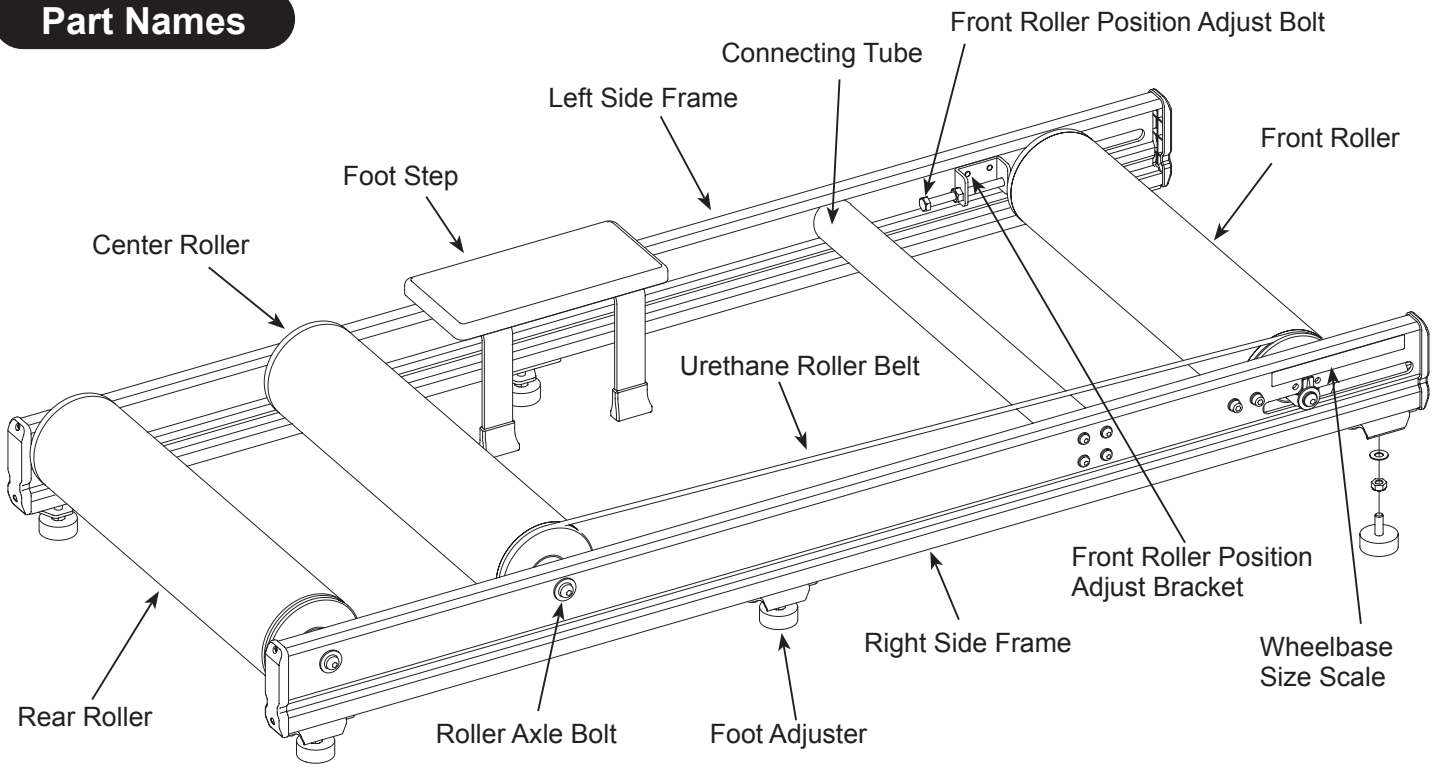

The Foot Step is fixed on the left side frame only because there is no hole on the right side frame. The roller belt is located on the opposite side to the step, so it is fixed on the right side only. It is not possible to change it to the left side by changing all roller drum directions.

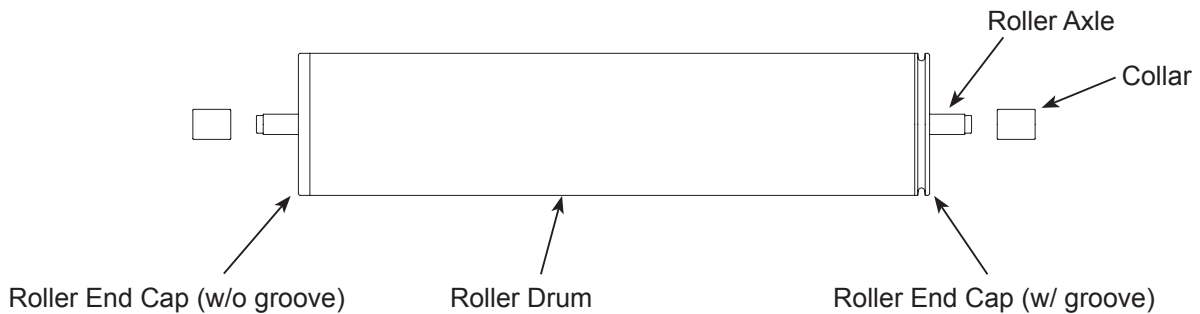

Adjusting Foot Height

Required Tool : 13mm Spanner

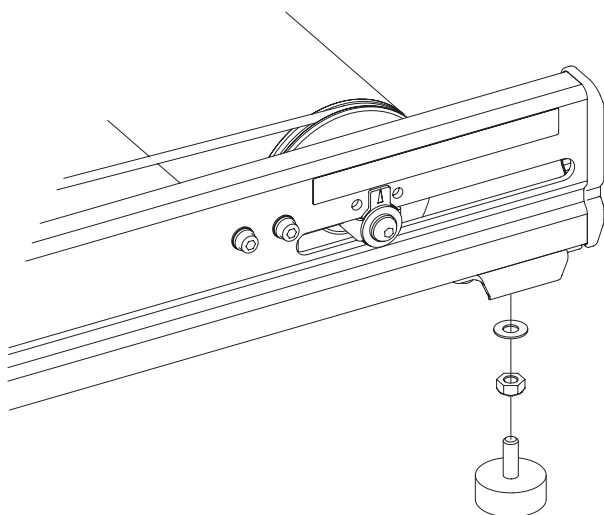

There are 6 Foot Adjusters in total under the R800 side frames. Each one is installed on each bottom bracket. Adjust the foot height individually as all 3 roller drums become completely horizontal and parallel when all 6 foot points touch the floor.

[How To Adjust Length]

1. Turn the Foot Adjuster counter-clockwise to extend the bolt length.
2. Turn the nut toward the bracket.
3. Tighten the nut with 13mm spanner securely to fix the position.

Adjusting Front Roller Position

Required Tools : 5mm Hex Wrench, 13mm Spanner

The front roller drum is fully position adjustable to fit your existing bike's wheelbase size perfectly.

- 1 Measure your bike's wheelbase size first prior to the following steps. Lay the R800 on the floor normally. Loosen both right and left side bolts of the front roller axle, and move the Front Roller forward.

The inside front roller bracket is fixed to the frame with two bolts. There are two locations for this bracket depending on the wheelbase size; the backside is for 950 – 1,020mm and the foreside is for 1,020 – 1,080mm. Change the bracket position if necessary.

Front Roller Position

If you are a beginner on triple roller trainer, you should set the front roller 10 – 15mm longer than your bike's wheelbase size (further from front roller axle).

If you are an experienced rider, you can set the front roller on the exact size of the wheelbase (just beneath the front wheel axle).

This would change the handling performance much quicker. If you don't want such quick handling, set the front roller a little further.

[Wheelbase Size : 950 – 1,020mm]

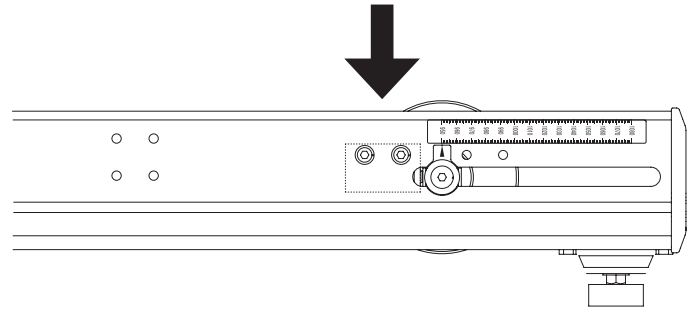

[Wheelbase Size : 1,020 – 1,080mm]

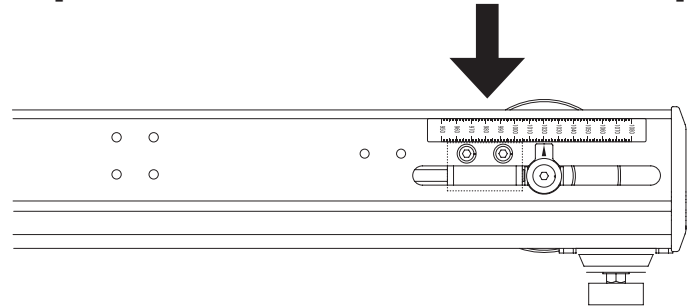

- 2 Prop the R800 against the wall. It enables to move the front roller by its own weight.

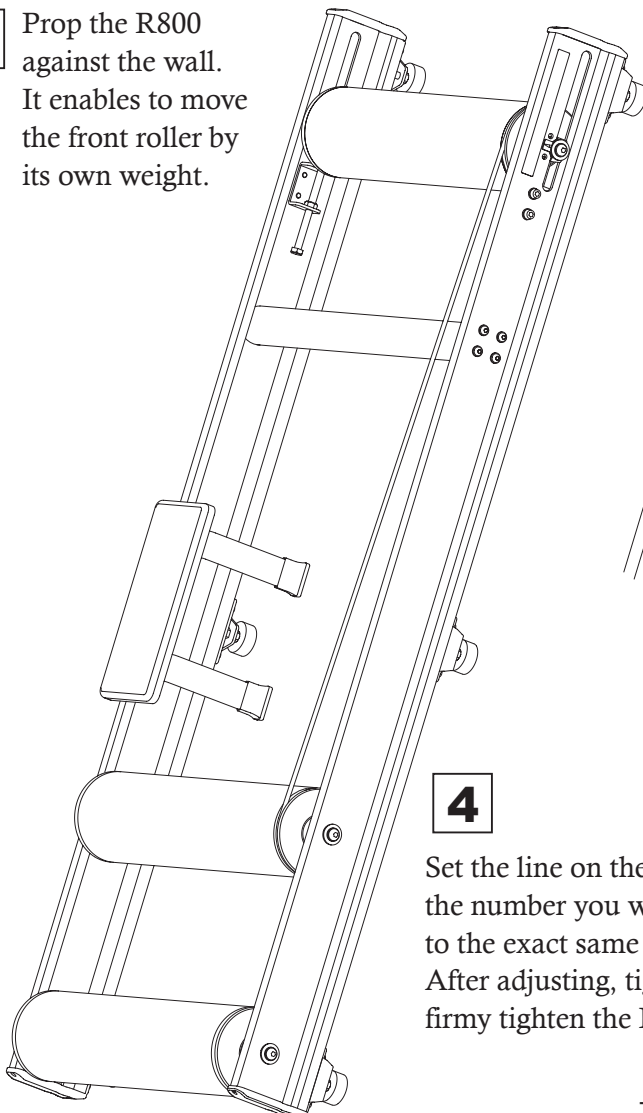

3

Loosen the Lock Nut by 13mm spanner, and turn the Adjusting Bolt to change the front roller position.

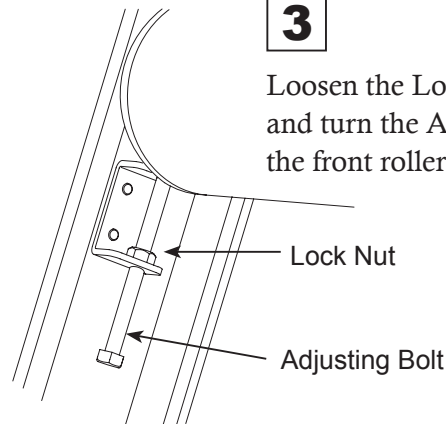

4

Set the line on the Wheelbase Indicator to the number you wish to set. You must set to the exact same number on both side. After adjusting, tighten the Lock Nut, and firmly tighten the Roller Axle Bolt.

Wheelbase Size Scale

Wheelbase Indicator

