

MINOURA

Direct Drive Bicycle Trainer
Instructions Manual

SmartTurbo KAGURA 神楽 LSD9200

(ver.1.0 2019/2)

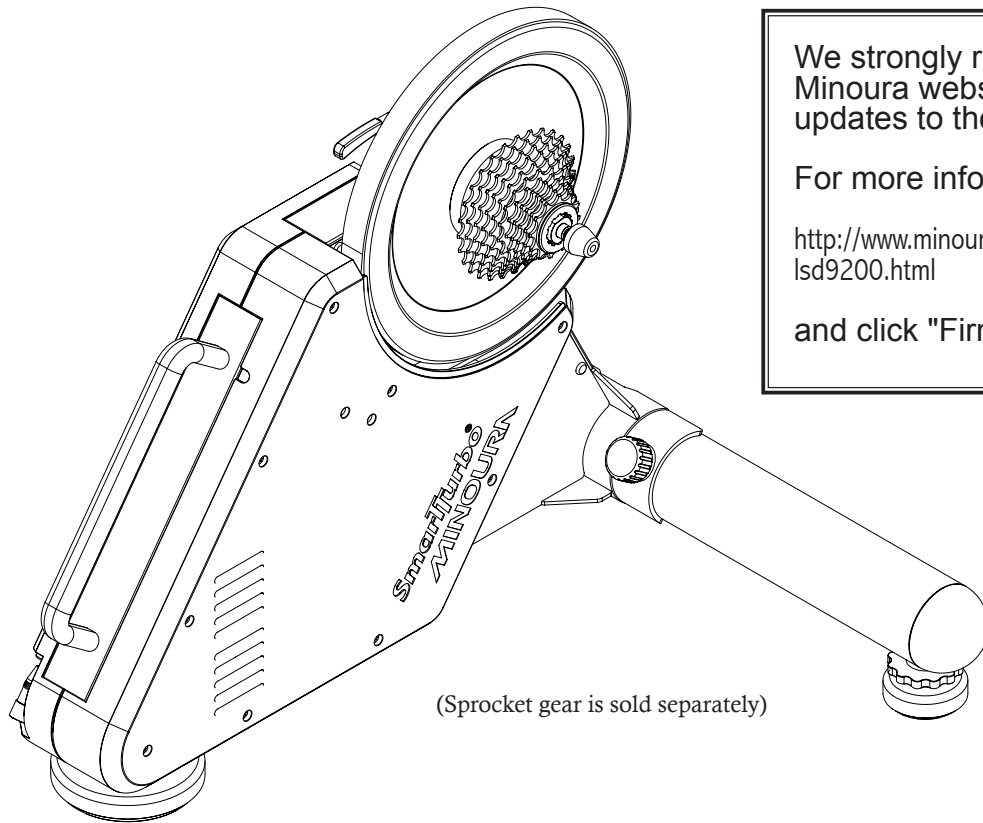

(Sprocket gear is sold separately)

We strongly recommend visiting the Minoura website regularly to check for updates to the Kagura firmware.

For more info, check out ...

<http://www.minoura.jp/english/trainer/smartturbo/lsd9200.html>

and click "Firmware Updates" button.

Merit of Direct Drive

LSD9200 "Kagura" Direct-Drive works with your current bike frame when you remove your wheel and mount your frame directly to the unit. Direct-Drive eliminates any potential power loss from traditional trainers because there is no chance of tire slippage and it transmits all the power you generate to the electric motor.

The precisely tuned resistance unit eliminates all the noise and vibrations usually associated with indoor trainers and provides a very smooth and quiet training session anytime.

Compatibility

Kagura-DD is compatible with Shimano and SRAM 8s, 9s, 10s and 11s. Campagnolo is currently NOT supported. You need to prepare the rear sprocket gear that fits your bike component separately.

The AC Adapter is capable with worldwide voltage 100V – 240V, but the electric plug design must fit your country's regulation. If you need to change the plug that came with your trainer, it is available as an option for purchase.

Contact

If you have any trouble with this product or request for maintenance, refer the attached "Minoura Limited Warranty Policy" card first, then contact the shop you originally purchased this product or the distributor in your country. The distributor list is found on our web site.

MINOURA North American Tech Center (for U.S. residents ONLY)

Hayward, California, U.S.A.

Phone: 1-510-538-8599 (8 am - 5 pm, Mon - Fri, PST)

Fax: 1-510-538-5899

Email: support@minourausa.com

MINOURA Japan Headquarters (for ALL customers)

134-1 Shimomiya, God, Anpachi, Gifu 503-2312 Japan

Fax: +81-584-27-7505

Email: minoura@minoura.jp

Web: www.minoura.jp

Made in Japan

Important Notes

Read Carefully Before Use

- Compatible only with the rear wheel hub width 130 & 135mm in 9mm Quick Release system, or 142 & 148mm in 12mm Thru Axle system. Any other sizes or systems cannot be used.
- Compatible with Shimano and SRAM 8s, 9s, 10s and 11s gears. Some Campagnolo gears are not be compatible. The sprocket gear doesn't come in the kit so you need to prepare it separately.
- You should shift the rear derailleur to the top before removing the rear wheel to make the set-up process easier.
- Place on flat and horizontal floor. Adjust all 3 feet correctly to set the bike vertical and level.
- Do not touch the spinning flywheel, belt or chain while training. This could cause serious injury or burns.
- Kagura DD weighs over 20 Kgs. Take caution when moving the trainer to avoid injury.
- Under high load training the belt might slip. If it does, it might need to be adjusted. Do not turn the locking Bolt-A more than one rotation. Doing so will lock the bolt.
- Kagura is a precisely manufactured electronic product. Misuse or abuse of the product may cause the unit to malfunction which will not be covered under the warranty. There are NO user serviceable parts on the Kagura DD. Disassembling the product in any way will immediately void any warranty.
- Make sure you assemble the quick release skewer or the thru axle correctly when installing the bike to the trainer. If it has been loosened, the bike may fall off while using.
- Be careful not to pinch your finger when retracting the Step-Bar.
- Make sure your Kagura-DD has the correct electric plug that fits your country's regulation. If not, replace the power cable to the appropriate one that is sold separately as an option.
- Do not apply any water, moisture or dust to the sensitive unit. Even if you use this product indoor, please keep it in clean and dry condition.
- This product outputs radio signals. Do not use in the area where any wireless devices are restricted, or near the person who has sensitive device such as a pacemaker.
- To protect the floor or the carpet from stain and sweat during workout, we recommend you to put a sheet or specially designed mat under the trainer and bike.
- Do not use any other AC Adapter supplied from third parties. Using wrong adapter could cause unexpected trouble on the Kagura unit such as burning or melting. If you experience a strange noise or smell, stop using Kagura-DD immediately and contact the retailer where you purchased this product. Do not try to disassemble the unit to repair without prior approval from Minoura.
- Any warranty will be void if you use Kagura-DD for any other purpose than instructed. Minoura offers 1-year limited warranty on this product from the date of your purchase for any problem caused by manufacturer's defect. Any damage or problem cause by transporting process or user's misuse, also the natural wear will not be covered under warranty. Read the enclosed "Minoura Limited Warranty Policy" card for more details. For the latest information, refer Minoura web site (<http://www.minoura.jp/english/>) regularly.

LSD9200 Contents

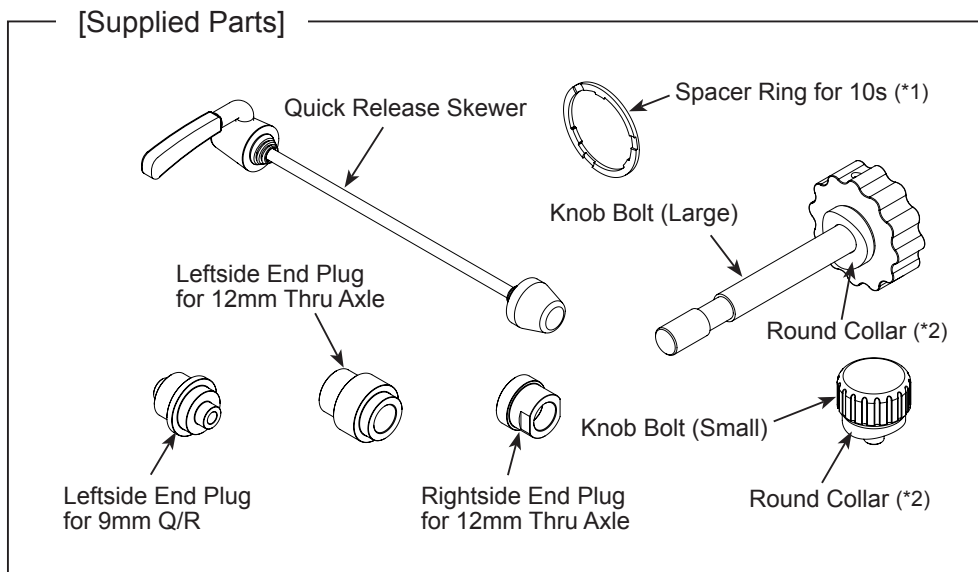
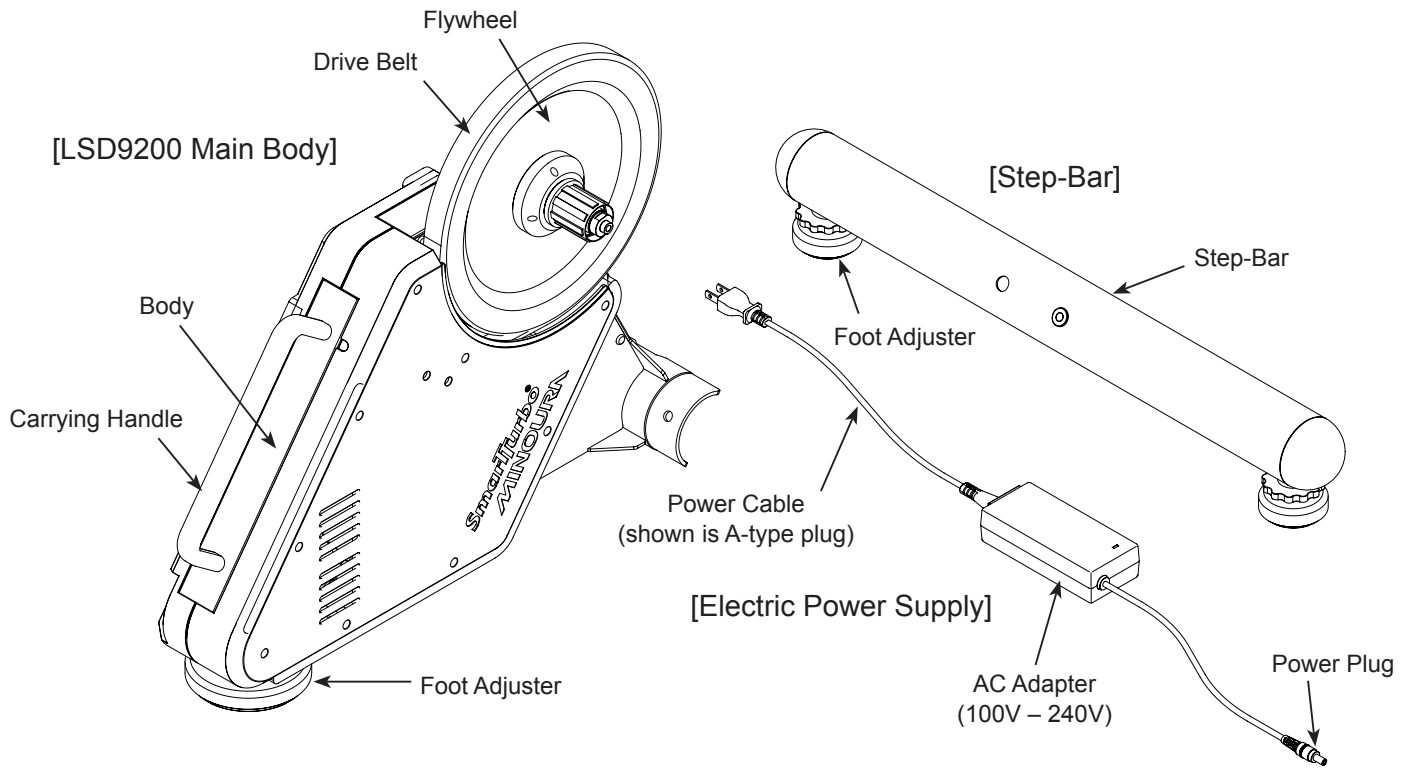



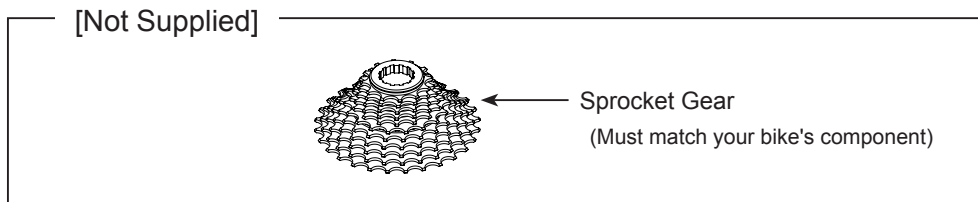

(*1 You will use on 8s and 9s too)
 (*2 Same size)

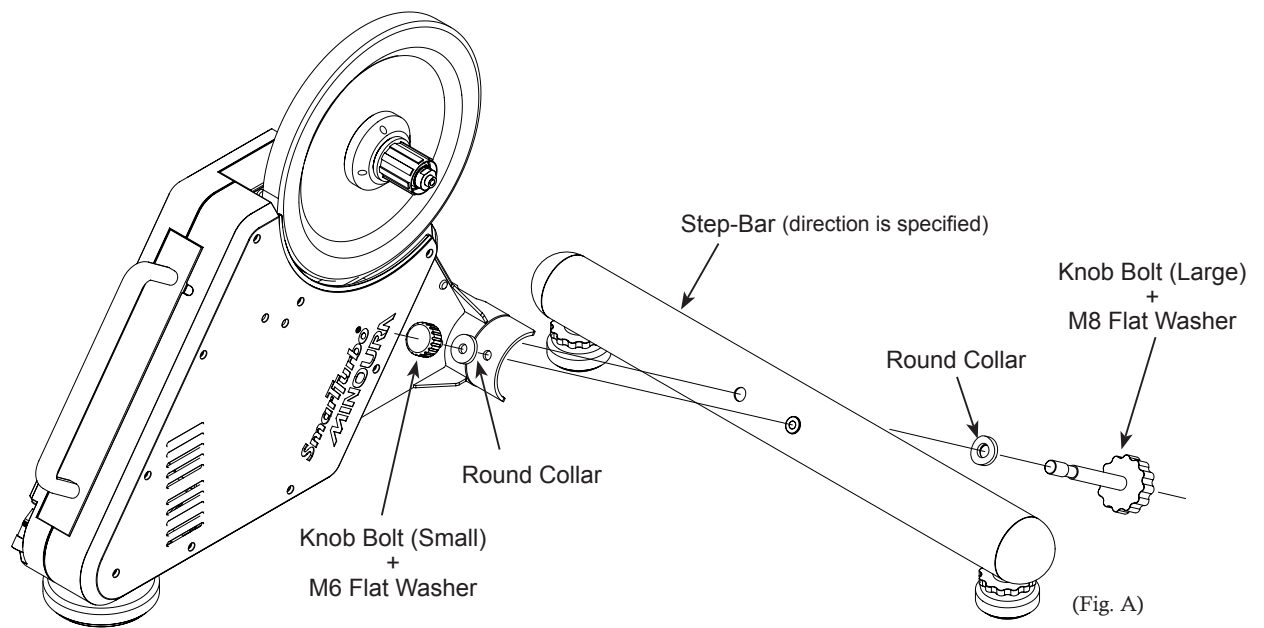

How To Install Step-Bar

Required Tool : Nothing



- 1** Install the Step-Bar to the Body. (Fig. A)
Put the Knob Bolt (Large) with the Round Collar into the plain hole on the Step-Bar, and screw it into the thread hole on the Body.
 -  *The direction of the Step-Bar is specified. You cannot install it in the wrong direction.*
 -  *The Round Collar works to spread the pressure from the bolt in order to avoid deforming the tube even if the bolt has been overtightened.*
 -  *You may find that the knob bolt spins freely and cannot be tightened further. This is by design. You can retighten by pushing knob bolt towards the thread hole.*
- 2** Put the Knob Bolt (Small) with the Round Collar into the thread hole on the Step-Bar through the small hole on the Body.
- 3** To retract the Step-Bar for storing compactly, remove the smaller Knob Bolt (Fig. B), loosen the larger Knob Bolt until it spins freely, and pull the Step-Bar (Fig. C).

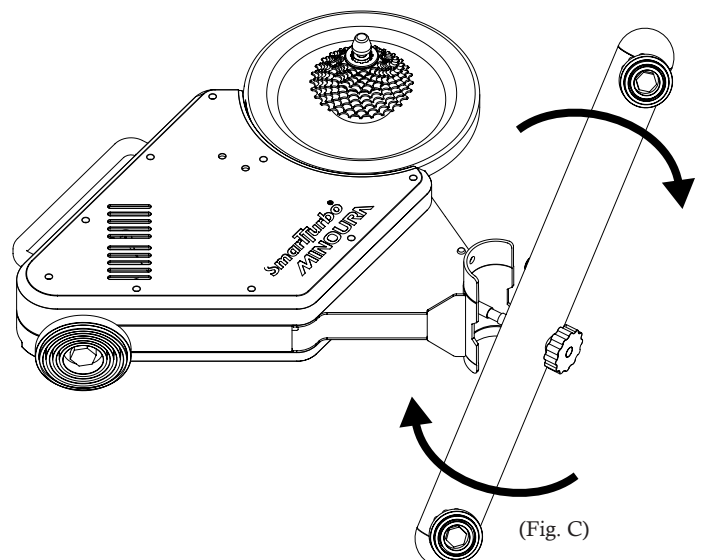
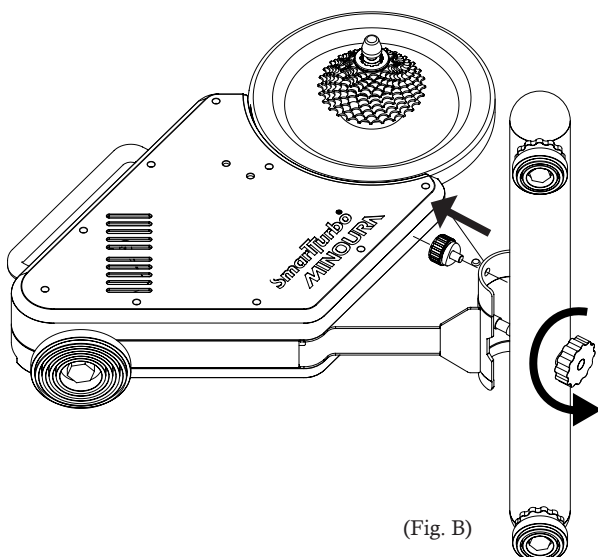

- 3** Turn the Step-Bar 90 degrees, set it on the grooves on the bracket, and tighten the larger Knob Bolt to hold. (Fig. D)

The smaller Knob Bolt can be stored in the thread hole on the Step-Bar.

Now the Kagura-DD is ready to be stored in the narrow area such as under the bed.

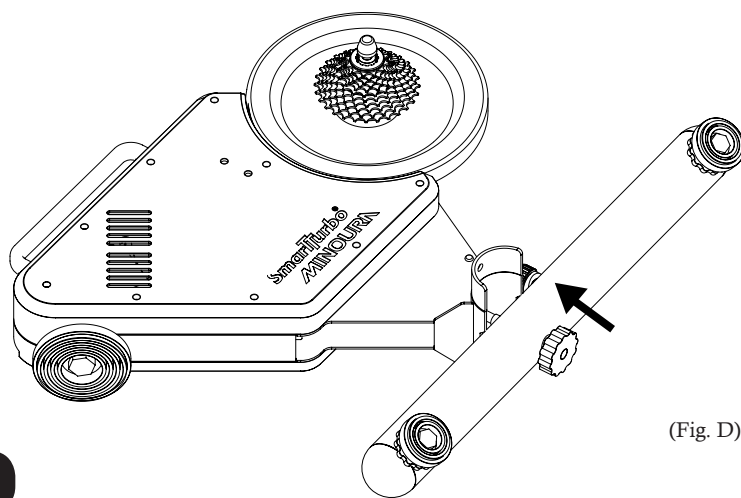

(Fig. D)

How To Install Sprocket Gear

Required Tools

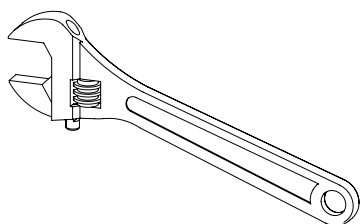

Adjustable Wrench
(Large size would work fine)



Lock Ring Tool
(must be compatible with your gear)

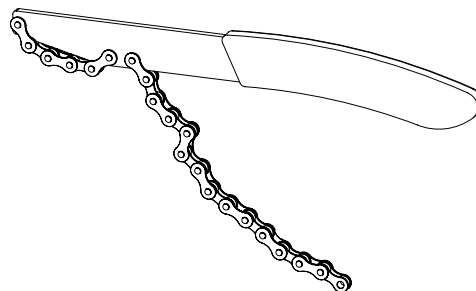

Sprocket Remover
(To remove the sprocket gear from the hub)

(Fig. E)

1

Insert the Sprocket Gear to the spline which is found on the right side of the Flywheel. (Fig. F)

One groove is wider than the other. This is the specific direction when the sprocket is installed.

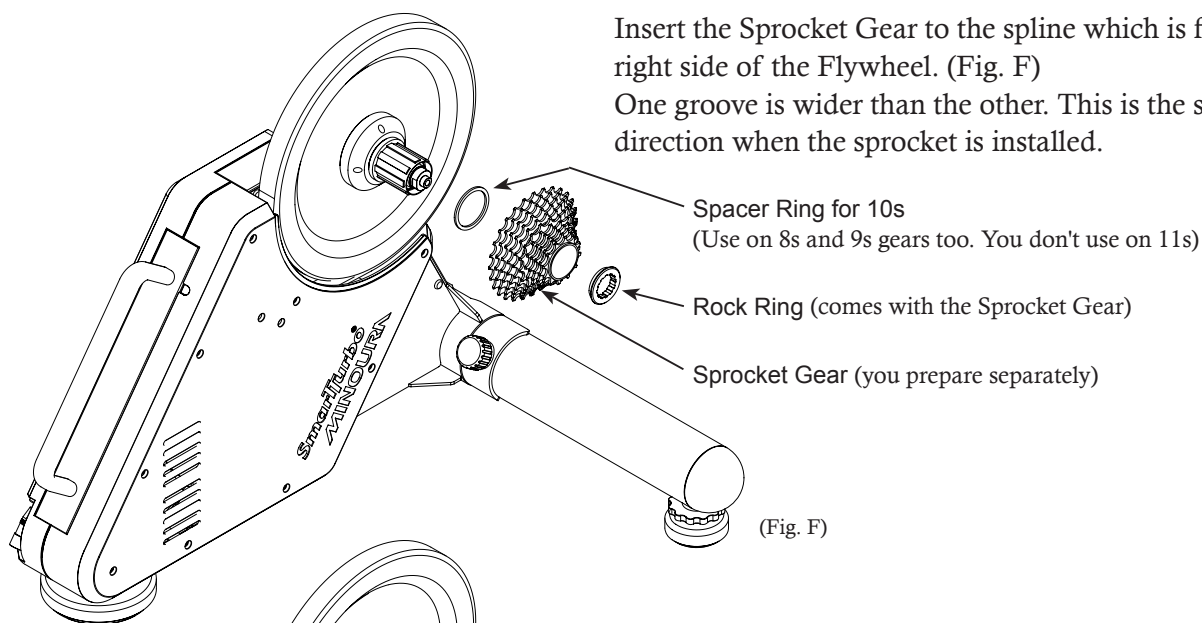

(Fig. F)

2

Fully insert the Lock Ring Tool into the Lock Ring, and turn clockwise to screw the Lock Ring into the hub.

Do not try to tighten the lock screw if it is at an angle. This will run the Lock Ring.

Hand tighten the Lock Ring first to make sure it is properly aligned. Then finish the job with your wrench (30 – 50 Nm).

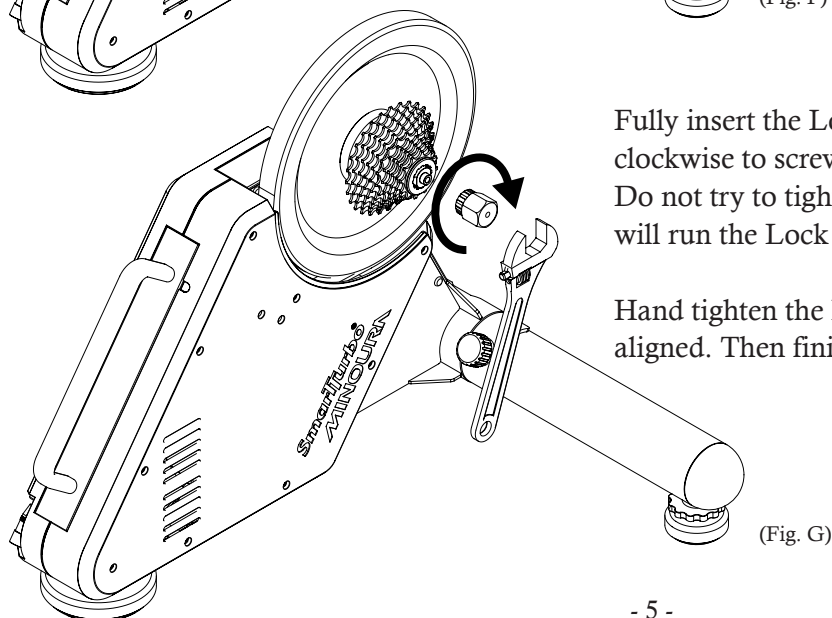

(Fig. G)

How To Replace To 12mm Thru Axle

The original hub on your Kagura-DD is preset for the standard 9mm Q/R.

If your bike is equipped with 12mm thru axle system, you must replace the right side hub end with the supplied special plug. (Fig. H)

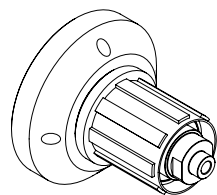

Hub end for standard 9mm Q/R system

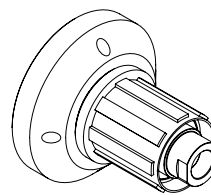

Hub end for 12mm Thru Axle

(Fig. H)

1

Apply the wrench to the original right side end plug, and turn it counter-clockwise to remove while holding the flywheel with your other hand. (Fig. I)

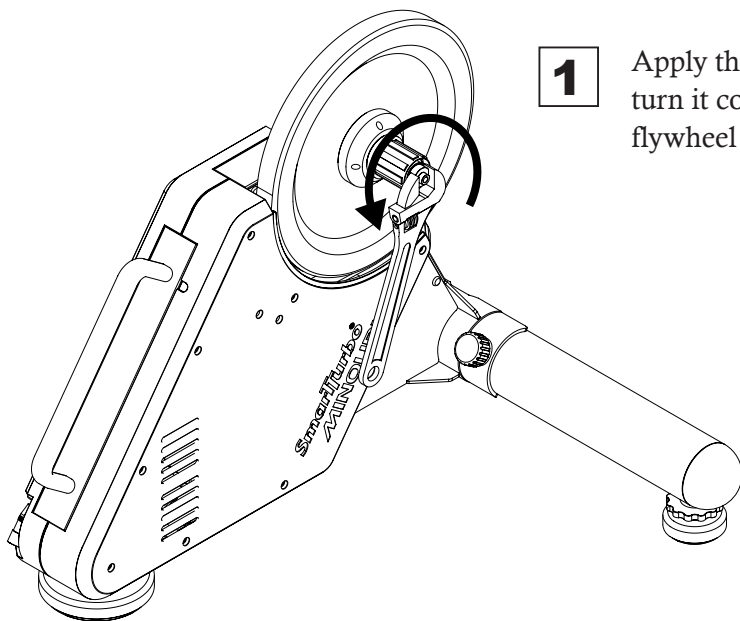

(Fig. I)

2

Install the supplied Rightside End Plug for 12mm Thru Axle to the hub.

Turn it by your hand first, then use the wrench to tighten firmly. (Fig. J)

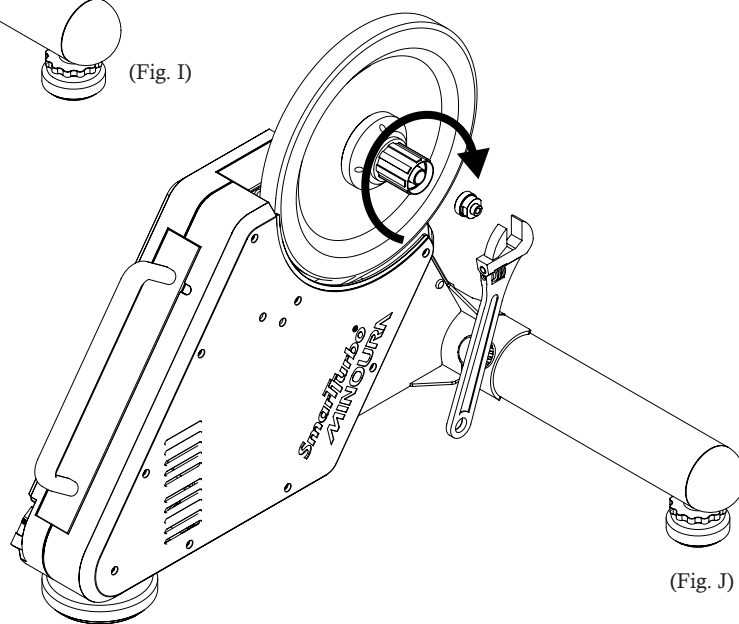

(Fig. J)

3

Installation is done.

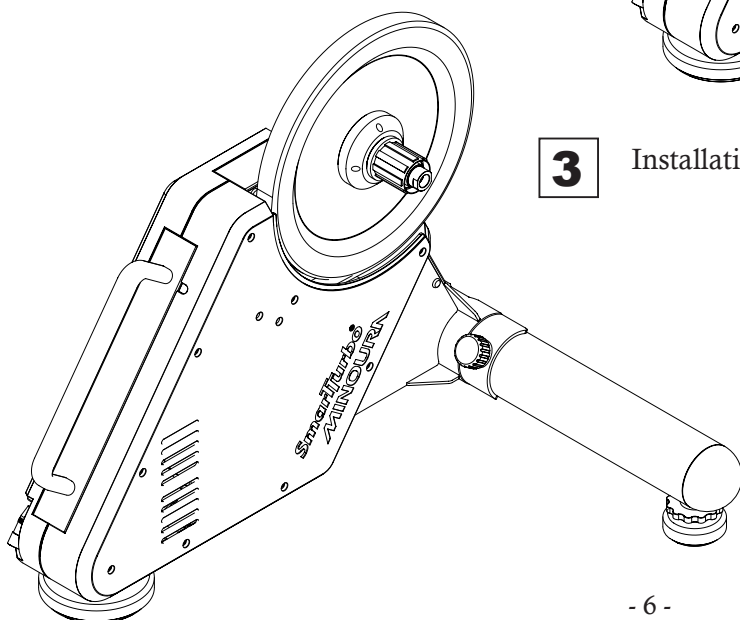

(Fig. K)

How To Remove Sprocket Gear

To remove the sprocket gear, you need a special tool called a Sprocket Remover together with the Lock Ring Tool.

Set the chain of the Sprocket Remover to the largest gear on the sprocket.

It means that turning the Lock Ring counter-clockwise will move the sprocket gear together in the same direction, so you need to hold it by this tool.

Fully insert the Lock Ring Tool into the Lock Ring, and apply the wrench to the tool.

Push both tools down at the same time and the gear will loosen.

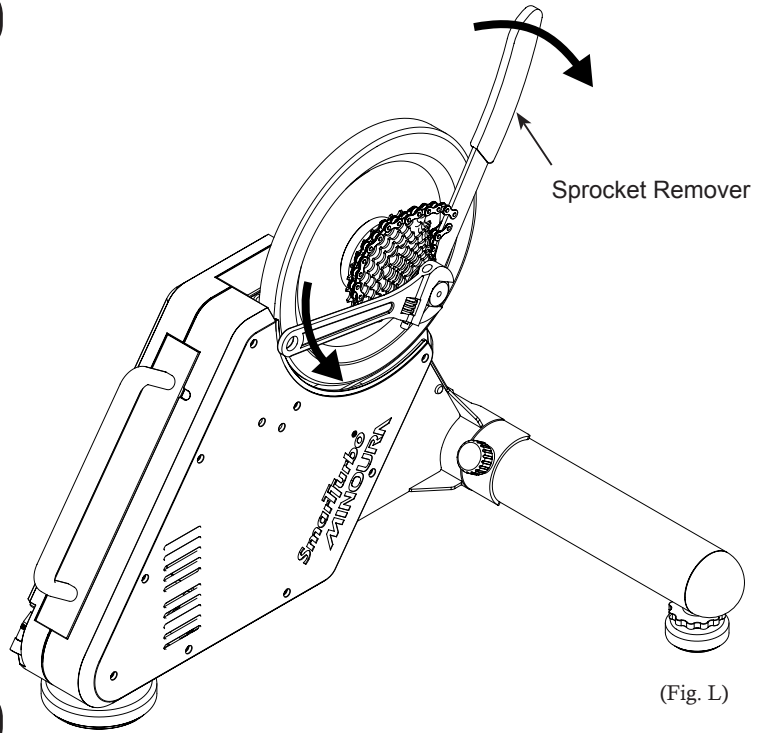

9mm Quick Release Skewer System

Installing 9mm Q/R Skewer

Insert the supplied Leftside End Plug for 9mm Q/R to the left end of the hub first. (Fig. N)

Disassemble the skewer. Put an Acorn Nut (be aware of the direction) on the shaft, and insert it through the hub from left side. (Fig. M)

Put another Acorn Nut on the shaft coming from the hub, and screw the nut.

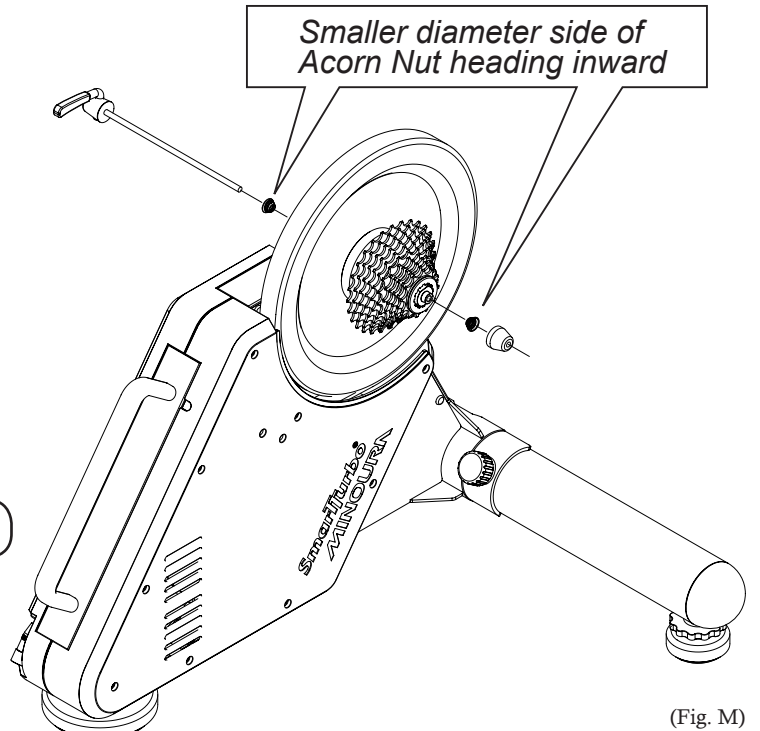

About Direction of Leftside End Plug

Compatible with the rear end width in 130mm and 135mm only.

Change the direction of the Leftside End Plug to the hub as shown in Fig. N.

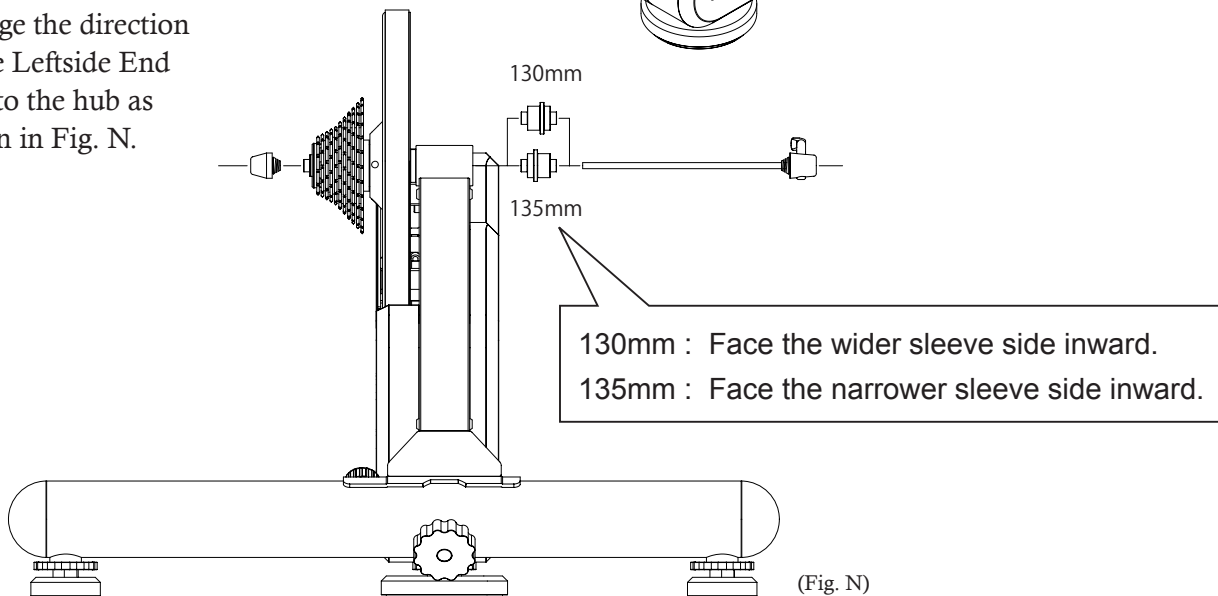

How To Mount a Bike on Your Kagura-DD

- 1** Fully open the Quick Release Skewer lever.
- 2** In order to make mounting the bike easier, set the rear derailleur to the top.
- 3** As same as installing the rear wheel onto the bike, hook the chain on the top gear, then set the bike frame on Kagura-DD gently. (Fig. O)
- 4** Make sure the bike frame has been set stable and vertical, close the skewer lever to hold. Adjust the skewer nut tightening correctly before closing the lever for your safety if necessary. (Fig. P)

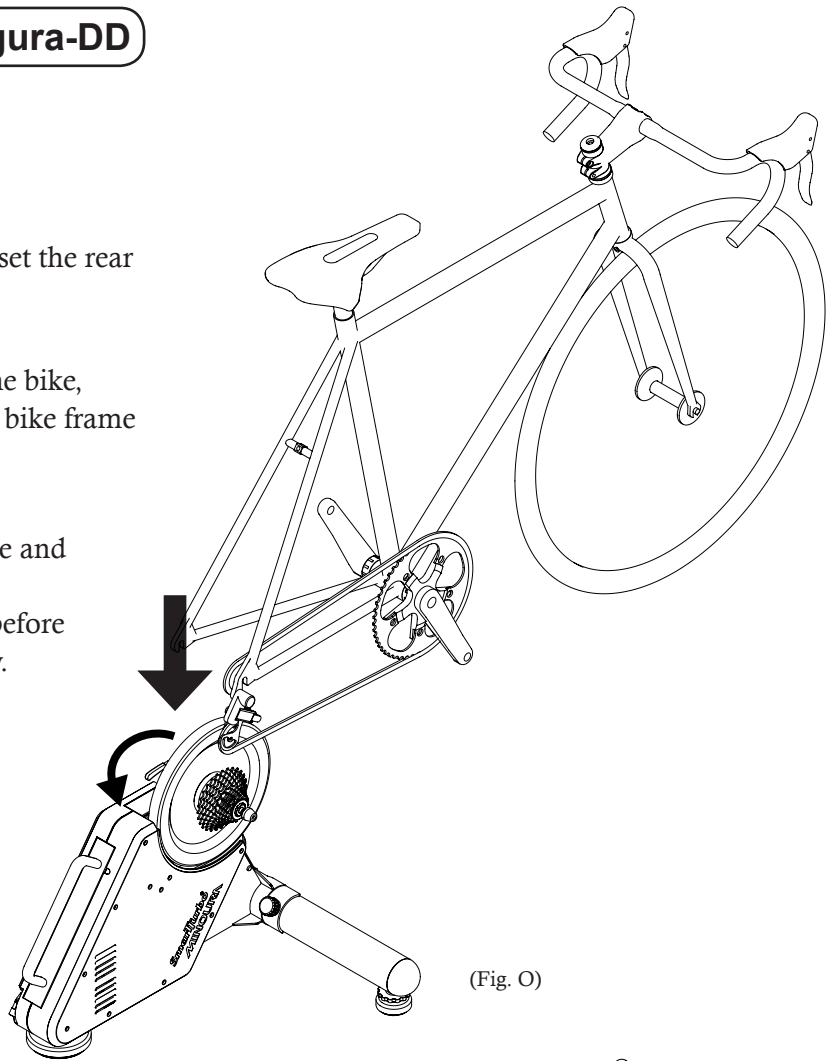

(Fig. O)



This instruction manual doesn't describe you how to use the quick release skewer. If you are not clear about this step, please seek advice of a trained bicycle mechanic to instruct you.

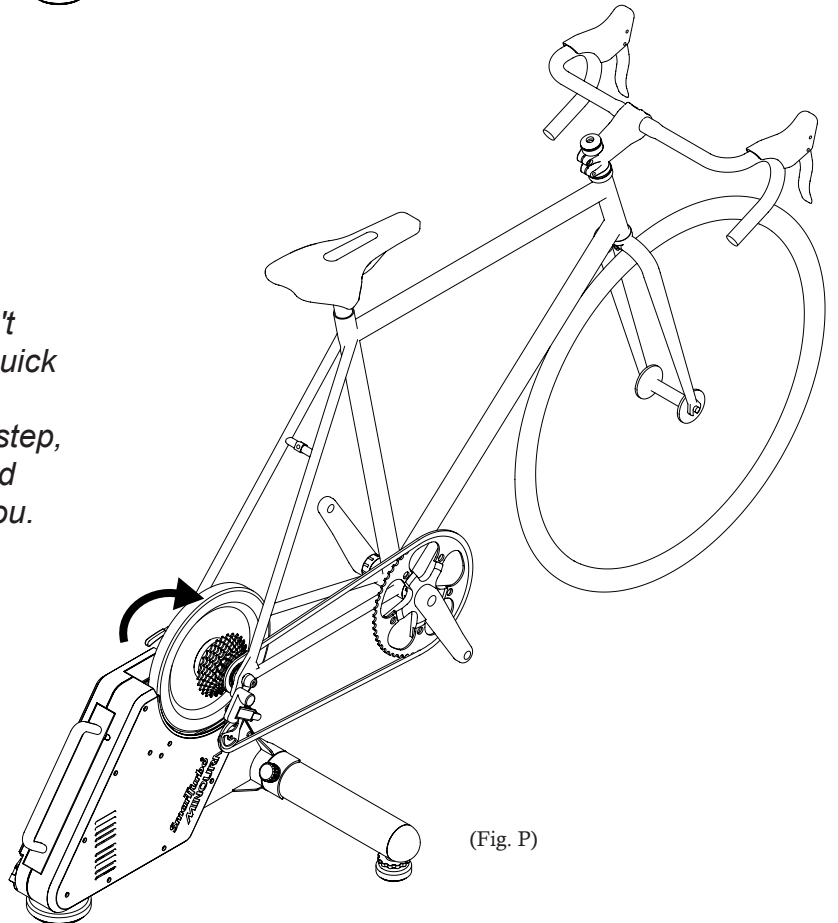

(Fig. P)

12mm Thru Axle System

About The Direction of The Leftside End Plug

Compatible with the rear end width in 142mm and 148mm only.

Change the direction of the Leftside End Plug to the hub as shown in Fig. Q.

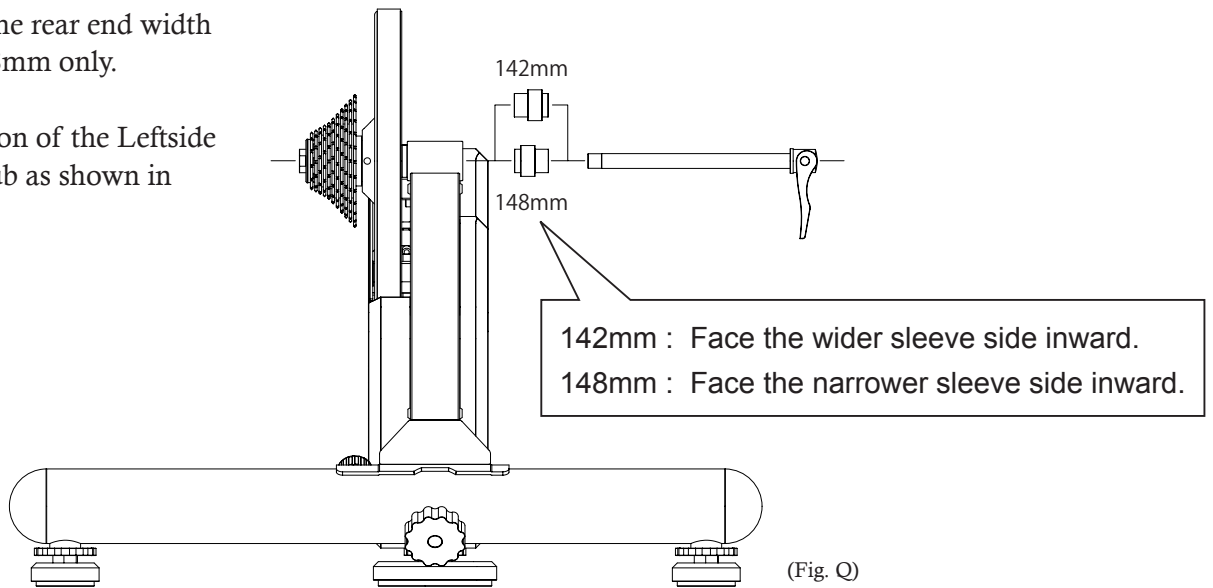

How To Install 12mm Thru Axle and How To Mount Your Bike

- 1** Insert the supplied Leftside End Plug for 12mm Thru Axle into the left side of the hub. (Fig. Q)
Make sure the other side end plug has been replaced with the supplied Rightside End Plug for 12mm Thru Axle. (Fig. H)
- 2** Hold the bike frame just above Kagura-DD and keep this position.
- 3** Put the axle shaft into the hole on the left side of the bike frame end, slowly get the frame down to align to the hub hole, and put the axle into the hub hole. Now the bike position has been fixed.
- 4** Screw the axle to the right side thread hole.
If your bike is equipped with a quick release type axle, adjust tightening and close the lever to hold securely.

Setting Foot Adjusters

Adjust all three foot adjusters under the body and step-bar to insure that the Kagura DD is stable and that your bike is vertical. (Fig. R)

The foot adjusters can be used to help level the bike, especially with larger 29" MTB wheels, by fully extending all three adjusters.

Turn the foot to adjust the length, and tighten the lock nut toward the body or the step-bar to fix.

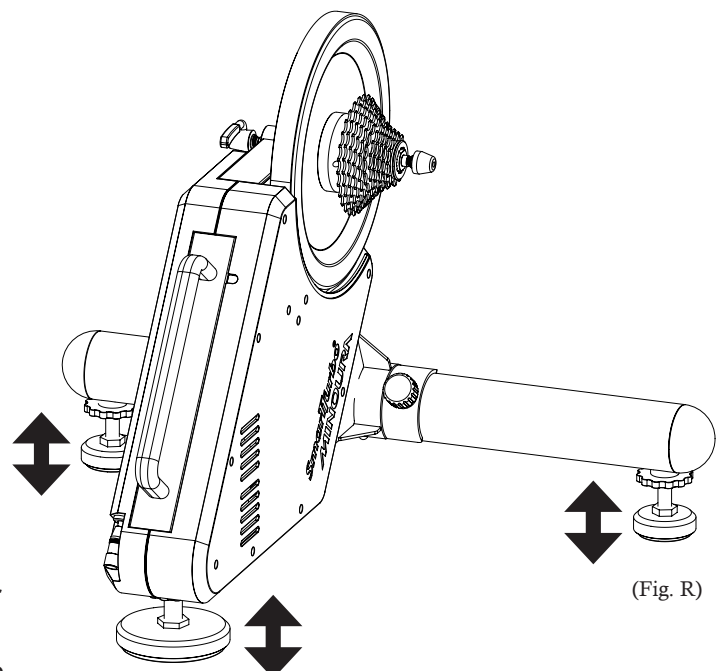

 Use the lock nut correctly to keep your Kagura-DD stable.

Turning Power On and Checking Status

Insert the round shape Power Plug to the connecting port on Kagura-DD, and plug in to the electric outlet, then the power will turn ON automatically. (Fig. S)

To turn off the power, simply pull out the plug.



Be careful to keep the cord away from anything it can become snagged or catch on. Undue pressure on the cord can pull the internal circuit board out of position and cause the unit to malfunction.



Connect the supplied AC adapter only. Do not use any other AC adapter supplied from third parties. It will void any warranty. Minoura will not be responsible for any trouble caused by using wrong devices.

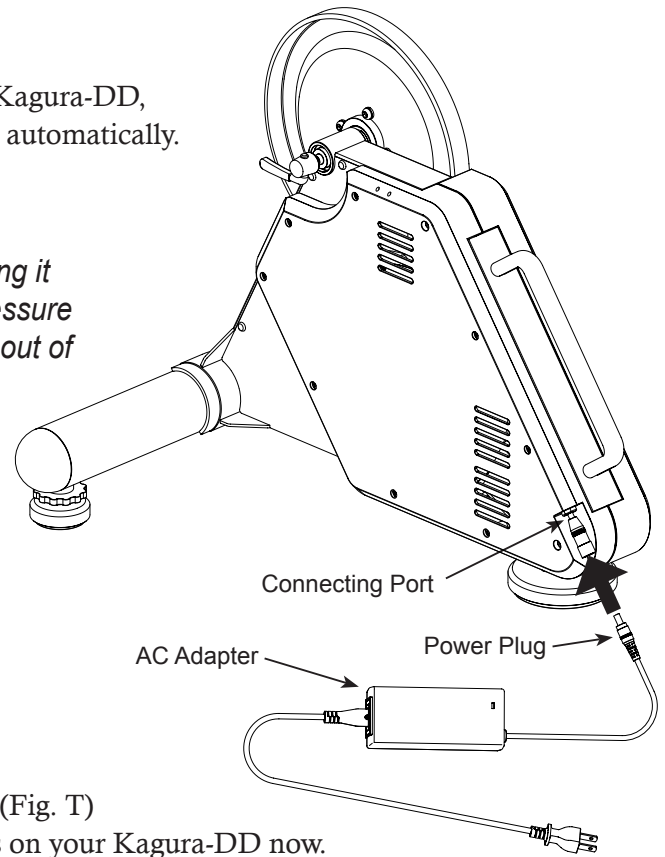

(Fig. S)

LED Patterns & Meanings

There are two LED lights (Blue and Red) on top of the body. (Fig. T)
Depending on the lighting patterns, it describes what happens on your Kagura-DD now.

● ● ● ● ● Blinking ■ Solid Light

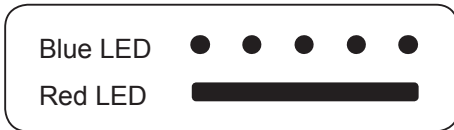

Power is ON. Awaiting Bluetooth pairing process



Successfully connected via Bluetooth
(Blue LED changes from blinking to solid)



Connected via Bluetooth, and the electric power is gaining

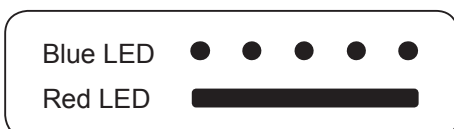

Connecting via ANT+ is completed
(Blue LED is still blinking. Optional ANT+ receiver is required for this connection.
Refer the application screen about the connecting status.)

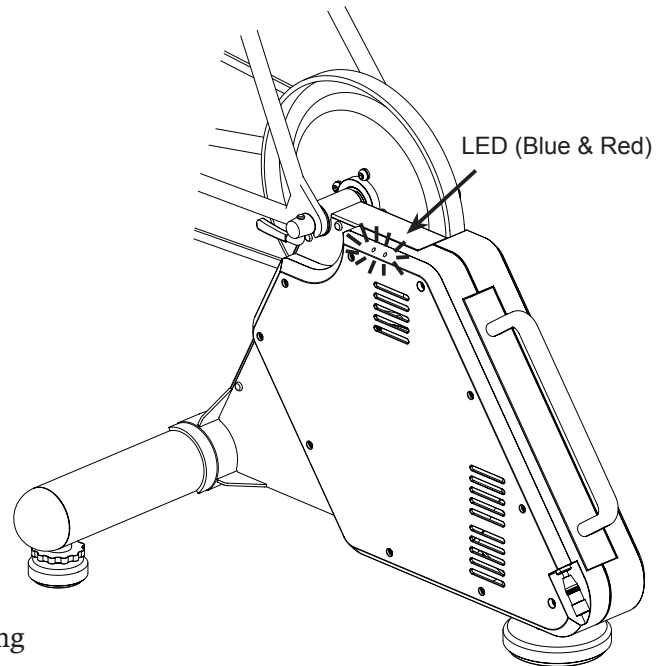

(Fig. T)



Minoura does not supply instructions on how to connect or pair your trainer with your chosen training app. Please refer to the app for instructions on how to connect the trainer for use with any given app.

The first step in trouble shooting your unit is to make sure you are using the most current version of our firmware. Update your firmware by going to the link posted above.

To get this service, you must be registered to Minoura as an official user.

How To Adjust Belt Tension

Required Tools: 3mm Hex Wrench
4mm Hex Wrench

As mentioned previously, it may become necessary to tighten the belt if you experience slippage, especially under heavy loads. To do this, remove the Side Cover and follow these steps.

This job can be done while the Side Cover sits on the body (Fig. U) once you understand the inside mechanism. (Fig. V)

- 1 Remove all 9 bolts that hold the Side Cover. (Fig. U)

 We use a special long bolt here. Do not misplace them.

- 2 Slightly loosen both Locking Bolt A and B by 4mm hex wrench.

 Do not overloosen the Locking Bolt-A more than one rotation. The Tension Adjusting Bolt pushes the Locking Bolt-A from sideward. At this moment, the thread area has been slightly damaged on the Bolt-A due to the pressure from the adjusting bolt. Therefore, the Locking Bolt-A will not be able to turn smoothly if it has been turned more than one rotation.

- 3 Turn the Belt Tension Adjusting Bolt approximately 1/2 turns clockwise with a 3mm hex wrench to give more tension to the belt.

 Too much belt tension will lead to premature wear and could cause other issues. Be careful not to over-tighten the belt.

- 4 Tighten both Locking Bolt A and B firmly and set the Side Cover.

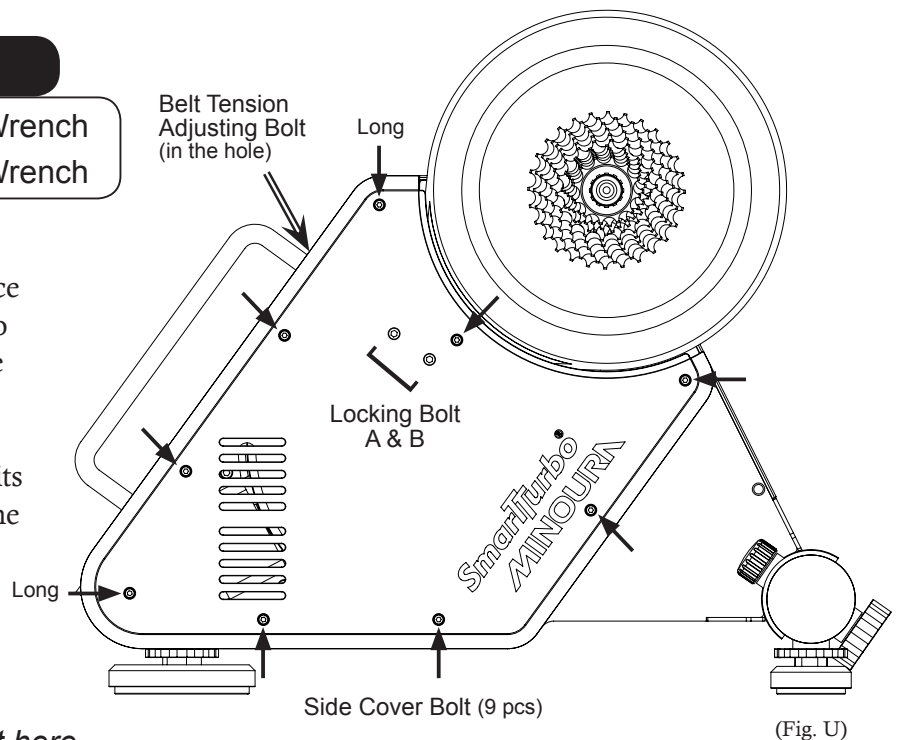

(Fig. U)

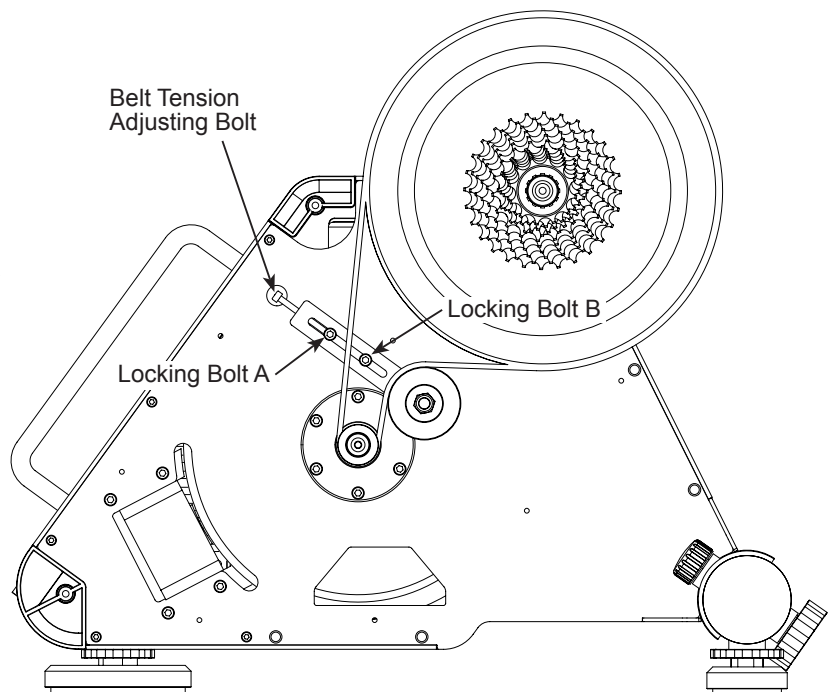

(inside mechanism after removing the side cover)

(Fig. V)